

# ABRASIVES



Brushes . . . . .	298-303
Cartridge Rolls . . . . .	336-337
Cut-Off Wheels . . . . .	324-325
Depressed Center Wheels . . . . .	326-327
Diamond Tools & Wheels . . . . .	319-323
Flap Discs . . . . .	328-329, 339
Flap Wheels . . . . .	333
Grinding Wheels . . . . .	304-316
Honing Tools . . . . .	298
Mounted Points . . . . .	317-318, 341
Non-Woven . . . . .	338-341
PSA Discs . . . . .	331
Quick Change Discs . . . . .	329, 332
Resin Fibre Discs . . . . .	330
Shop Rolls & Sheets . . . . .	334-335

# Flex-Hone® Tools



## Flex-Hone® Tools

- Use on valve guides, cam bearing bores, main bearing bores, lifter bores, pneumatic cylinders, engine cylinders, brake cylinders, drums and rotors, hydraulic guides, pumps, and compressors.

- The Flex-Hone® Tool is resilient, flexible honing tool with soft cutting action. It's unique construction allows the abrasive globules or "stones" to float, assuring the tool will be self-centering, self-aligning to the bore and self-compensating for wear.

- The Flex-Hone® Tool removes peaks and other imperfections in cylinder walls, creating a desirable plateaued finish. The result is reduction in localized heat and friction and improved performance.

## Silicon Carbide

FLEX-HONE MODEL NO.	BORE SIZE	120 GRIT		180 GRIT		240 GRIT		320 GRIT	
		ORDER NO.	PRICE EACH	ORDER NO.	PRICE EACH	ORDER NO.	PRICE EACH	ORDER NO.	PRICE EACH
BC-4MM	(0.157)	-	-	5690-151	\$16.90	5690-152	\$17.90	5690-153	\$25.30
BC-4.5MM	(0.177)	-	-	5690-171	16.60	5690-172	17.60	5690-173	24.90
BC-3/16"	(4.75MM)	-	-	5690-181	16.80	5690-182	17.30	5690-183	24.50
BC-5MM	(0.197)	5690-190	\$15.80	5690-191	15.80	5690-192	16.80	5690-193	23.70
BC-5.5MM	(0.217)	5690-210	16.10	5690-211	16.10	5690-212	17.10	5690-213	24.10
BC-6.4MM	(0.25)	5690-250	10.60	5690-251	10.60	5690-252	11.20	5690-253	15.90
BC-7MM	(0.276)	5690-270	10.70	5690-271	10.70	5690-272	11.30	5690-273	16.00
BC-8MM	(0.315)	5690-310	11.20	5690-311	11.20	5690-312	11.90	5690-313	16.80
BC-9MM	(0.354)	5690-350	11.70	5690-351	11.70	5690-352	12.40	5690-353	17.50
BC-9.5MM	(0.375)	5690-370	12.90	5690-371	12.90	5690-372	13.70	5690-373	19.40
BC-10MM	(0.394)	5690-390	13.10	5690-391	13.10	5690-392	13.80	5690-393	19.60
BC-11MM	(0.433)	5690-430	13.30	5690-431	13.30	5690-432	14.10	5690-433	20.00
BC-12MM	(0.472)	5690-470	13.60	5690-471	13.60	5690-472	14.40	5690-473	20.40
BC-1/2"	(12.7MM)	5690-500	13.90	5690-501	13.90	5690-502	14.70	5690-503	20.80
BC-14MM	(0.552)	5690-550	13.90	5690-551	13.90	5690-552	14.80	5690-553	20.90
BC-5/8"	(16MM)	5690-620	14.70	5690-621	14.70	5690-622	15.60	5690-623	22.10
BC-18MM	(0.709)	5690-700	15.10	5690-701	15.10	5690-702	16.00	5690-703	22.70
BC-3/4"	(19MM)	5690-750	15.50	5690-751	15.50	5690-752	16.40	5690-753	23.30
BC-20MM	(0.787)	5690-780	15.60	5690-781	15.60	5690-782	16.50	5690-783	23.40
BC-7/8"	(22MM)	5690-870	15.70	5690-871	15.70	5690-872	16.60	5690-873	23.50
BC-15/16"	(23.8MM)	5690-930	16.20	5690-931	16.20	5690-932	17.20	5690-933	24.30
BC-1"	(25.4MM)	5691-000	16.70	5691-001	16.70	5691-002	17.70	5691-003	25.10
BC-1-1/8"	(29MM)	5691-120	17.60	5691-121	17.60	5691-122	18.60	5691-123	26.40
BC-1-1/4"	(31.8MM)	5691-250	19.00	5691-251	19.00	5691-252	20.10	5691-253	28.50
BC1-3/8"	(35MM)	5691-370	19.50	5691-371	19.50	5691-372	20.70	5691-373	29.30
BC-1-1/2"	(38MM)	5691-500	20.90	5691-501	20.90	5691-502	22.10	5691-503	31.30
BC-1-5/8"	(41MM)	5691-620	20.90	5691-621	20.90	5691-622	22.20	5691-623	31.40
BC-1-3/4"	(45MM)	5691-750	21.80	5691-751	21.80	5691-752	23.20	5691-753	32.80
BC-1-7/8"	(48MM)	5691-870	22.20	5691-871	22.20	5691-872	23.60	5691-873	33.40
BC-2"	(51MM)	5692-000	22.60	5692-001	22.60	5692-002	24.00	5692-003	34.00
BC-2-1/8"	(54MM)	5692-120	23.60	5692-121	23.60	5692-122	25.00	5692-123	35.40
BC-2-1/4"	(57MM)	5692-250	24.50	5692-251	24.50	5692-252	26.00	5692-253	36.80
BC-2-3/8"	(60MM)	5692-370	25.50	5692-371	25.50	5692-372	27.00	5692-373	38.20
BC-2-1/2"	(64MM)	5692-500	26.40	5692-501	26.40	5692-502	28.00	5692-503	39.60
BC-2-5/8"	(67MM)	5692-620	27.80	5692-621	27.80	5692-622	29.50	5692-623	41.70
BC-2-3/4"	(70MM)	5692-750	29.20	5692-751	29.20	5692-752	30.90	5692-753	43.80
BC-2-7/8"	(73MM)	5692-870	31.50	5692-871	31.50	5692-872	33.40	5692-873	47.30
BC-3"	(76MM)	5693-000	33.80	5693-001	33.80	5693-002	35.90	5693-003	50.80
GB-3-1/4"	(83MM)	5693-100	38.20	5693-101	38.20	5693-102	40.50	5693-103	57.30
GB-3-1/2"	(89MM)	5693-120	40.70	5693-121	40.70	5693-122	43.20	5693-123	61.10
GB-3-3/4"	(95MM)	5693-140	43.80	5693-141	43.80	5693-142	46.50	5693-143	65.80
GB-4-1/8"	(105MM)	5693-160	46.60	5693-161	46.60	5693-162	49.40	5693-163	70.00
GB-4-5/8"	(118MM)	5693-180	52.00	5693-181	52.00	5693-182	55.10	5693-183	78.00

FLEX-HONE MODEL NO.	BORE SIZE	120 GRIT		180 GRIT		240 GRIT		320 GRIT	
		ORDER NO.	PRICE EACH	ORDER NO.	PRICE EACH	ORDER NO.	PRICE EACH	ORDER NO.	PRICE EACH
GBD-3"	(76MM)	5693-300	\$55.40	5693-301	\$ 55.40	5693-302	\$ 58.70	5693-303	\$83.10
GBD-3-1/4"	(83MM)	5693-320	57.20	5693-321	57.20	5693-322	60.60	5693-323	85.70
GBD-3-1/2"	(89MM)	5693-340	58.90	5693-341	58.90	5693-342	62.40	5693-343	88.30
GBD-3-3/4"	(95MM)	5693-360	63.10	5693-361	63.10	5693-362	66.90	5693-363	94.70
GBD-4"	(101MM)	5693-380	67.40	5693-381	67.40	5693-382	71.40	5693-383	101.00
GBD-4-1/4"	(108MM)	5693-400	72.00	5693-401	72.00	5693-402	76.30	5693-403	107.50
GBD-4-1/2"	(114MM)	5693-420	76.60	5693-421	76.60	5693-422	81.20	5693-423	115.00
GBD-5"	(127MM)	5693-440	87.20	5693-441	87.20	5693-442	92.50	5693-443	130.80
GBD-5-1/2"	(140MM)	5693-460	95.70	5693-461	95.70	5693-462	101.40	5693-463	143.50
GBD-6"	(152MM)	5693-480	103.70	5693-481	103.70	5693-482	109.80	5693-483	155.50
GBD-6-1/2"	(165MM)	5693-500	111.70	5693-501	111.70	5693-502	118.40	5693-503	167.60
GBD-7"	(178MM)	5693-520	121.80	5693-521	121.80	5693-522	129.10	5693-523	182.70
GBD-7-1/2"	(190MM)	5693-540	134.00	5693-541	134.00	5693-542	142.00	5693-543	200.90
GBD-8"	(203MM)	5693-560	146.40	5693-561	146.40	5693-562	155.20	5693-563	219.70

## Standard Duty Flex-Hones®

- 4mm – 3/16" are 6" OAL
- 5mm – 3" are 8" OAL
- 3-1/4" – 4-5/8" are 13-1/2"



## Heavy Duty Flex-Hones®

- 3" – 4-1/2" are 13-1/2" OAL
- 5" – 8" are 17-1/2" OAL



## Trulock Crimped Wire Wheel Brushes



DIA.	WIRE SIZE	ARBOR HOLE	TRIM LENGTH	FACE WIDTH	MAX SAFE FREE SPEED (RPM)	STD. PKG.	ITEM NO.	PRICE EACH
Narrow Face								
4	.008	1/2-3/8†	7/8	1/2	6,000	2	6500-104	\$32.08
4	.0095	1/2-3/8†	7/8	1/2	6,000	2	6500-124	17.57
6	.008	5/8-1/2†	1-7/16	3/4	6,000	10	6501-045	26.39
6	.014	5/8-1/2†	1-7/16	3/4	6,000	10	6501-075	19.23
8	.0118	5/8-1/2†	2-1/16	3/4	6,000	2	6501-165	30.30
8	.014	5/8-1/2†	2-1/16	1/2	6,000	2	6501-175	26.79
10	.0118	3/4	2-1/2	3/4	4,000	2	6501-248	39.90
10	.014	3/4	2-1/2	3/4	4,000	2	6501-258	38.32
Medium Face								
6	.0118	2††	1-1/8	1	6,000	1	6506-070	36.98
6	.014	2††	1-1/8	1	6,000	1	6506-080	37.33
8	.0118	2††	1-3/8	1	4,000	1	6506-110	56.14
8	.014	2††	1-3/8	1	4,000	1	6506-120	55.84
10	.0118	2*	2	1-1/8	3,600	1	6506-150	92.26
10	.014	2**	2	1-1/8	3,600	1	6506-160	90.69
Wide Face								
6	.0118	2††	1-1/8	1-1/8	6,000	1	6503-060	56.52
8	.0118	2††	1-3/8	1-3/8	4,000	1	6503-140	87.18
10	.0118	2††	1-7/8	1-5/8	4,000	1	6503-190	152.92

† Features plastic snap-out arbor hole adapter

†† Other arbor holes available using metal adapter. Please specify.

\* 1/2 x 1/4 Double keyway and uses metal adapter.

## Dualife Knot Type Wire Wheel Brushes



### Standard Twist

DIA.	WIRE SIZE	ARBOR HOLE	TRIM LENGTH	FACE WIDTH	MAX SAFE FREE SPEED (RPM)	STD. PKG.	ITEM NO.	PRICE EACH
4	.014	1/2-3/8†	7/8	1/2	20,000	10	6508-044	\$19.73
4	.020	1/2-3/8†	7/8	1/2	20,000	10	6508-064	19.49
6	.016	5/8-1/2†	1-3/8	1/2	9,000	10	6508-095	30.22
8	.016	5/8-1/2†	1-5/8	5/8	6,000	2	6508-145	45.46
8	.023	5/8-1/2†	1-5/8	5/8	6,000	2	6508-155	44.17
10	.016	1-1/4*	1-3/4	3/4	4,500	2	6508-189	64.48
12	.014	1-1/4*	2-3/4	3/4	3,600	1	6508-209	83.65
12	.020	1-1/4*	2-1/4	5/8	5,000	2	6509-719	107.16
15	.016	1-1/4*	4-1/4	7/8	3,600	2	6508-249	107.81

† Features plastic snap-out arbor hole adapter

\* 5/16 x 5/32 Double Keyway

Other diameters, arbor hole, or wire sizes available on request.

## Orbitor Bench Grinder Brushes



Features plastic snap-out arbor hole adapter.

Other arbor hole available on request

DIA.	WIRE SIZE	ARBOR HOLE	TRIM LENGTH	FACE WIDTH	MAX SAFE FREE SPEED (RPM)	STD. PKG.	ITEM NO.	PRICE EACH
Narrow Face								
6	.014	5/8-1/2	1-1/16	5/8	6,000	1	6502-325	\$22.20
7	.014	5/8-1/2	1-9/16	3/4	6,000	1	6502-335	27.32
Medium Face								
6	.014	5/8-1/2	1-1/8	7/8	6,000	1	6506-645	27.58
7	.014	5/8-1/2	1-5/8	7/8	6,000	1	6506-655	32.15

## Copper Center Wire Wheels



### Wire Fill

DIA.	WIRE SIZE	ARBOR HOLE	TRIM LENGTH	FACE WIDTH	MAX SAFE FREE SPEED (RPM)	STD. PKG.	ITEM NO.	PRICE EACH
2	.006	1/2	1/2	3/8	20,000	10	6515-433	\$7.36
2	.014	1/2-3/8	1/2	3/8	20,000	10	6515-473	5.42
3	.006	5/8	15/16	1/2	20,000	10	6515-637	10.66
3	.014	1/2	1	1/2	20,000	10	6515-553	7.41
3	.014	1/2-3/8	1	1/2	20,000	10	6515-573	6.49

## Metal Adapters For Wire Wheel Brushes

(Used in pairs)

ADAPTER ARBOR SIZE	STD. PKG.	ORDER SIZE	PRICE EACH
1/2	1 Pr.	6503-809	\$1.77
5/8	1 Pr.	6503-810	1.77
3/4	1 Pr.	6503-811	1.77
7/8	1 Pr.	6503-824	1.77
1	1 Pr.	6503-812	1.77
1 1/4	1 Pr.	6503-813	1.77
1-1/2	1 Pr.	6503-814	2.14



## Standard Twist Stainless Steel

DIA.	WIRE SIZE	ARBOR HOLE	TRIM LENGTH	FACE WIDTH	MAX SAFE FREE SPEED (RPM)	STD. PKG.	ITEM NO.	PRICE EACH
4	.020	1/2-3/8	7/8	1/2	20,000	10	6508-314	\$37.50
6	.016	5/8-1/2	1-3/8	1/2	9,000	2	6508-345	68.51
8	.016	5/8-1/2	1-5/8	5/8	6,000	2	6508-395	101.68

## Standard Twist-Wide Face (Double Sections)

DIA.	WIRE SIZE	ARBOR HOLE	TRIM LENGTH	FACE WIDTH	MAX SAFE FREE SPEED (RPM)	STD. PKG.	ITEM NO.	PRICE EACH
6	.016	2	1-3/8	7/8	9,000	5	6509-180	\$68.52
8	.016	2	1-5/8	1	6,000	1	6509-430	99.68
10	.016	2	1-3/4	1-1/4	4,500	1	6509-480	133.07
12	.014	2	2-3/4	1-1/4	3,600	1	6509-530	173.65

Other arbor holes available using metal adapter

### Cup Brushes



**Knot Type - Single Row**

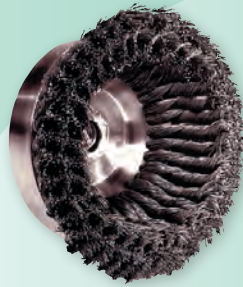

**Knot Type - Double Row**



**Crimped Wire**

DIA.	WIRE SIZE	ARBOR HOLE	TRIM LENGTH	MAX SAFE FREE SPEED (RPM)	STD. PKG.	ITEM NO.	PRICE EACH
<b>Knot Type – Single Row</b>							
4	.014	5/8-11	1-1/4	9,000	1	6512-306	\$32.48
4	.023	5/8-11	1-1/4	9,000	1	6512-316	29.47
4	.035	5/8-11	1-1/4	9,000	1	6512-326	29.55
6	.014	5/8-11	1-1/2	6,600	1	6512-356	63.18
6	.023	5/8-11	1-1/2	6,600	1	6512-376	59.24
6	.035	5/8-11	1-1/2	6,600	1	6512-396	58.17
<b>Knot Type – Double Row – Heavy Duty</b>							
6	.023	5/8-11	1-3/8	6,600	1	6512-556	82.52
<b>Crimped Wire Medium &amp; Light Duty Applications</b>							
4	.014	5/8-11	1-3/8	9,000	1	6514-026	26.50
4	.020	5/8-11	1-3/8	9,000	1	6514-036	24.87
6	.014	5/8-11	1-1/4	6,600	1	6514-066	45.13
6	.020	5/8-11	1-1/4	6,600	1	6514-076	40.59
<b>Knot Type – Single Row – Heavy Duty – Stainless Steel</b>							
4	.014	5/8-11	1-1/4	9,000	1	6512-406	67.61
4	.023	5/8-11	1-1/4	9,000	1	6512-416	64.78
4	.014	5/8-11	1-3/8	6,600	1	6512-456	131.36
6	.023	5/8-11	1-3/8	6,600	1	6512-476	113.84

## Mighty-Mite Brushes for Small Angle Grinders

### Knot Type Wire Wheel- Stringer Bead Twist

DIA.	WIRE SIZE	ARBOR HOLE	TRIM LENGTH	FACE WIDTH	MAX SAFE FREE SPEED (RPM)	STD. PKG.	ITEM NO.	PRICE EACH
4	.020	5/8-11	7/8	3/16	20,000	5	6513-131	\$17.09
4	.020	M 10 x 1.25	7/8	3/16	20,000	5	6513-125	17.09
4	Stainless .020	M 10 x 1.25	7/8	3/16	20,000	5	6513-132	28.95
4	Stainless .020	5/8-11	7/8	3/16	20,000	5	6513-138	29.24

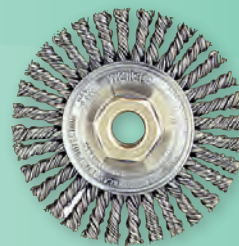

### Knot Type - Wire Wheel Cable Twist



### Crimped Wire Cup Brush



DIA.	WIRE SIZE	ARBOR HOLE	TRIM LENGTH	FACE WIDTH	MAX SAFE FREE SPEED (RPM)	STD. PKG.	ITEM NO.	PRICE EACH
4	.020	5/8-11	7/8	1/4	20,000	5	6513-266	\$21.36

DIA.	WIRE SIZE	ARBOR HOLE	TRIM LENGTH	MAX SAFE FREE SPEED (RPM)	STD. PKG.	ITEM NO.	PRICE EACH
3	.014	M10 x 1.25	7/8	14,000	1	6513-240	\$18.24
3	.014	5/8-11	7/8	14,000	1	6513-245	18.13

### Knot Type - Cup Brush Single Row



DIA.	WIRE SIZE	ARBOR HOLE	TRIM LENGTH	MAX SAFE FREE SPEED (RPM)	STD. PKG.	ITEM NO.	PRICE EACH
2-3/4	.020	M10 x 1.25	7/8	14,000	1	6513-281	\$19.54
2-3/4	.020	1/2-13	7/8	14,000	1	6513-285	19.54
2-3/4	.020	5/8-11	7/8	14,000	1	6513-286	19.54

## Nylox Filament Brushes

### Nylox Wheels Crimped Filament

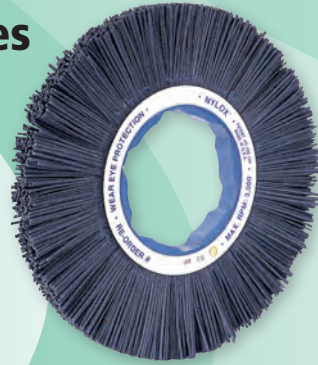

2

### Crimped Filament Disc Silicon Carbide – Composite Hub

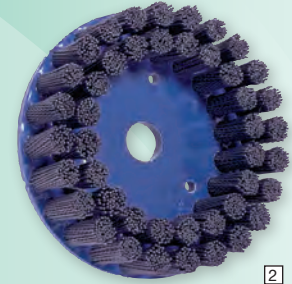

2

DIA.	ARBOR HOLE	FILAMENT DIAM. AND GRIT SIZE	TRIM LENGTH	FACE WIDTH	THICKNESS THROUGH ARBOR	MAX SAFE FREE SPEED (RPM)	STD. PKG.	ITEM NO.	PRICE EACH
6	2	.002/320	1-1/4	1	1-1/16	5,000	2	6583-010	\$61.82
6	2	.035/180	1-1/4	1	1-1/16	5,000	2	6583-030	61.82
6	2	.040/120	1-1/4	1	1-1/16	5,000	2	6583-040	61.82
6	2	.040/80	1-1/4	1	1-1/16	5,000	2	6583-050	61.82
8	2	.002/320	2-1/4	1	3/4	5,000	2	6583-110	85.58
8	2	.035/180	2-1/4	1	3/4	5,000	2	6583-130	85.58
8	2	.040/120	2-1/4	1	3/4	5,000	2	6583-140	85.58
8	2	.040/80	2-1/4	1	3/4	5,000	2	6583-150	85.58
10	2	.002/320	3	1	1-1/16	4,500	2	6583-310	114.43
10	2	.035/180	3	1	1-1/16	4,500	2	6583-330	114.43
10	2	.040/120	3	1	1-1/16	4,500	2	6583-340	114.43
10	2	.040/80	3	1	1-1/16	4,500	2	6583-350	114.43

Other arbor holes available using metal adapter. Please specify.



2

### Nylox Cup Brushes

DIA.	ARBOR HOLE	FILAMENT DIAM. AND GRIT SIZE	TRIM LENGTH	THICKNESS THROUGH ARBOR	MAX SAFE FREE SPEED (RPM)	STD. PKG.	ITEM NO.	PRICE EACH
2-3/4	1/4 Stem	.022/320	1-1/4	1-1/16	6,000	1	6514-401	\$34.20
2-3/4	1/4 Stem	.035/180	1-1/4	1-1/16	6,000	1	6514-403	34.00
2-3/4	1/4 Stem	.040/120	1-1/4	1-1/16	6,000	1	6514-404	34.00
3-1/2	5/8-11	.035/180	1-1/2	3/4	12,000	1	6514-413	47.33
3-1/2	5/8-11	.040/120	1-1/2	3/4	8,000	1	6514-414	47.33
5	5/8-11	.040/120	1-1/4	3/4	8,000	1	6514-576	77.22
6	5/8-11	.040/120	1-1/4	1-1/16	6,500	1	6514-516	83.35
6	5/8-11	.040/80	1-1/4	1-1/16	6,000	1	6514-506	83.35



2

### Nylox Tube Brushes

DIA.	FILAMENT DIAM. AND GRIT SIZE	BRUSH LENGTH	STEM DIA.	OVERALL LENGTH	STD. PKG.	ITEM NO.	PRICE EACH
1/4	.002/320	1-1/2	1/8	4	10	6521-126	\$8.66
3/8	.035/180	1-1/2	1/8	4	10	6521-128	8.78
1/2	.040/120	2	5/32	5	10	6521-130	7.67
5/8	.002/320	2	7/32	5	10	6521-132	8.07
3/4	.035/180	2-1/2	7/32	5-1/2	10	6521-134	8.18
7/8	.040/120	2-1/2	1/4	5-1/2	10	6521-136	8.69
1	.040/120	2-1/2	1/4	5-1/2	10	6521-138	8.27
1-1/8	.002/320	2-1/2	1/4	5-1/2	10	6521-302	7.60
1-1/4	.035/180	2-1/2	1/4	5-1/2	10	6521-306	8.83
1-1/2	.040/120	2-1/2	1/4	5-1/2	10	6521-309	9.21

### Rectangular Filament Disc (.045 x .090) Silicon Carbide– Composite Hub

2

DIAMETER INCHES	ARBOR HOLE	GRIT SIZE	TRIM LENGTH	MAX. RPM	ITEM NO.	PRICE EACH
4"	7/8"	180	1-1/2"	2,500	6585-822	\$116.13
4"	7/8"	120	1-1/2"	2,500	6585-824	116.13
4"	7/8"	80	1-1/2"	2,500	6585-826	116.13
6"	7/8"	120	1-1/2"	2,000	6585-860	159.82
6"	7/8"	80	1-1/2"	2,000	6585-862	159.82
8"	7/8"	120	1-1/2"	2,000	6585-920	254.52
8"	7/8"	80	1-1/2"	2,000	6585-922	254.52



### Nylon Disc Brush Drive Arbors

Mounts Weiler disc brushes to any type of milling machine or CNC machine

4

DESCRIPTION	ITEM NO.	PRICE EACH
For 4" diameter disc brushes with 1-1/4" diameter bolt circle	6507-700	\$200.01
For 6" diameter disc brushes with 3" diameter bolt circle	6507-701	244.48
For 8" diameter disc brushes with 3" diameter bolt circle	6507-702	265.15
Standard 3/4" diameter shaft, 2" long. Standard 7/8" diameter shouldered spindle.		

**Power and Hand Tube Brushes**



**Single Stem, Single Spiral "STS" Type - Eye Handle**

DIA.	WIRE SIZE	BRUSH LENGTH	STEM DIAM.	OVERALL LENGTH	STD. PKG.	ITEM NO.	PRICE EACH
3/16	.003	1-1/2	3/32	7	10	6521-090	\$4.85
3/16	.005	1-1/2	3/32	7	10	6521-091	4.85
1/4	.003	1-1/2	3/32	7	10	6521-092	5.45
1/4	.005	1-1/2	3/32	7	10	6521-093	4.71
3/8	.004	2	1/8	8	10	6521-094	4.90
3/8	.006	2	1/8	8	10	6521-095	3.86
1/2	.004	2	1/8	8	10	6521-096	4.90
1/2	.006	2	1/8	8	10	6521-097	3.86

**Single Stem, Round "SM" Type - Stainless Steel Stem**



Steel Wire							
1/4	.004	1	1/8	3-1/2	10	6521-072	\$4.26
3/8	.004	1	1/8	3-1/2	10	6521-073	4.33
3/8	.008	1	3/16	3-1/2	10	6521-264	3.71
1/2	.005	1	3/16	3-1/2	10	6521-074	3.96
5/8	.005	1	3/16	3-1/2	10	6521-075	4.11
5/8	.008	1	3/16	3-1/2	10	6521-265	4.70
3/4	.006	1	7/32	3-1/2	10	6521-076	4.70
3/4	.008	1	7/32	3-1/2	10	6521-266	4.65
7/8	.006	1	7/32	3-1/2	10	6521-077	4.86
1	.005	1	1/4	3-1/2	10	6521-078	5.35
1-1/8	.008	1	1/4	3-1/2	10	6521-079	5.35
1-1/4	.008	1	1/4	3-1/2	10	6521-080	5.35
Stainless Steel Wire							
1/4	.004	1	1/8	3-1/2	10	6521-081	4.93
3/8	.008	1	1/8	3-1/2	10	6521-240	4.11
1/2	.005	1	3/16	3-1/2	10	6521-083	5.03
5/8	.005	1	3/16	3-1/2	10	6521-084	5.03
3/4	.006	1	7/32	3-1/2	10	6521-085	5.03
7/8	.006	1	7/32	3-1/2	10	6521-086	5.07
1	.008	1	1/4	3-1/2	10	6521-087	6.09

**Single Stem, Double Spiral "DS" Type**



Single Stem, Double Spiral "DS" Type							
1/2	.006	2	5/32	5	10	6521-107	\$10.20
5/8	.008	2	7/32	5	10	6521-109	10.36
3/4	.0104	2-1/2	1/4	5-1/2	10	6521-111	10.54
7/8	.0104	2-1/2	1/4	5-1/2	10	6521-113	10.94
1	.0104	2-1/2	1/4	5-1/2	10	6521-115	10.74
1-1/4	.0104	2-1/2	1/4	5-1/2	10	6521-167	11.22

**End Brushes**



**Solid End**



**Knot Type**



**Crimped Wire Cup**

							STAINLESS	
DIA.	WIRE SIZE	TRIM LENGTH	MAX SAFE FREE SPEED (RPM)	STD. PKG.	ITEM NO.	PRICE EACH	ITEM NO.	PRICE EACH
Solid End								
1/2	.006	7/8	25,000	10	6510-001	\$7.22	6510-013	\$9.90
1/2	.0104	7/8	25,000	10	6510-002	6.31	6510-014	8.65
1/2	.014	7/8	25,000	10	6510-003	6.31	6510-015	8.54
1/2	.020	7/8	25,000	10	6510-004	6.00	6510-016	8.47
3/4	.006	7/8	22,000	10	6510-005	11.10	6510-017	12.45
3/4	.0104	7/8	22,000	10	6510-006	8.26	6510-018	11.30
3/4	.014	7/8	22,000	10	6510-007	8.08	6510-019	11.30
3/4	.020	7/8	22,000	10	6510-008	7.59	6510-020	11.02
1	.006	7/8	22,000	10	6510-009	14.96	6510-021	19.05
1	.0104	7/8	22,000	10	6510-010	9.72	6510-022	16.62
1	.014	7/8	22,000	10	6510-011	9.72	6510-023	16.24
1	.020	7/8	22,000	10	6510-012	9.18	6510-024	15.90
Knot Type								
3/4	.020	7/8	20,000	10	6510-026	14.27	6510-030	22.05
1-1/8	.014	7/8	20,000	10	6510-027	14.91	6510-031	28.50
1-1/8	.020	7/8	20,000	10	6510-028	14.66	6510-032	25.54
Crimped Wire Cup Brushes								
1-3/4"	.006	3/4"	13,000	10	6514-300	11.30	-	-
1-3/4"	.0118	3/4"	13,000	10	6514-301	9.97	6514-304	20.56
2-3/4"	.0118	7/8"	6,000	1	6514-302	15.28	-	-

**Conflex Narrow Face Crimped Wire Wheel**



							STAINLESS	
DIA.	WIRE SIZE	TRIM LENGTH	MAX SAFE FREE SPEED (RPM)	STD. PKG.	ITEM NO.	PRICE EACH	ITEM NO.	PRICE EACH
2	.006	1/2	20,000	10	6517-609	\$13.97	-	-
2	.0118	1/2	20,000	10	6517-610	12.48	-	-
2 1/2	.006	3/4	20,000	10	6517-612	16.02	6517-611	\$19.20
2 1/2	.014	3/4	20,000	10	6517-614	10.63	-	-
3	.008	1	20,000	10	6517-615	16.26	-	-
3	.0118	1	20,000	10	6517-616	12.34	-	-
3	.014	1	20,000	10	6517-617	11.52	6517-618	26.59

# Maintenance Brushes

## Hand Wire Scratch Brushes

### Curved Handle



FILL MATERIAL	NUMBER OF ROWS	BLOCK SIZE	BRUSH PART	TRIM LENGTH	STD. PKG.	ITEM NO.	PRICE EACH
.012 STEEL	3 x 19	13 x 1/2 x 1	6	1	12	6525-150	\$2.02
.012 SS	3 x 19	13 x 1/2 x 1	6	1	12	6525-154	3.04
.012 STEEL†	3 x 19	14 x 7/8	5-1/2	1-3/16	12	6544-055	3.73
.012 SS	4 x 18	14 x 1-1/8	6	1	12	6525-202	4.10
.012 STEEL†	4 x 19	14 x 1-1/8	6	1-3/16	12	6544-058	4.67

† With Scraper

### Block Type



FILL MATERIAL	NUMBER OF ROWS	BLOCK SIZE	TRIM LENGTH	STD. PKG.	ITEM NO.	PRICE EACH
.012 STEEL	6 x 19	7-1/4 x 2-1/4	1-5/8	12	6544-067	\$5.88

### Scraper Type



FILL MATERIAL	NUMBER OF ROWS	BLOCK SIZE	BRUSH PART	TRIM LENGTH	STD. PKG.	ITEM NO.	PRICE EACH
.012 STEEL	4 x 11	11 x 1-1/2	5	1-5/8	12	6525-211	\$3.30

### Shoe Handle



FILL MATERIAL	NUMBER OF ROWS	BLOCK SIZE	BRUSH PART	TRIM LENGTH	STD. PKG.	ITEM NO.	PRICE EACH
.012 STEEL	4 x 16	10 x 1	5	1	12	6525-100	\$2.18
.012 SS	4 x 16	10 x 1	5	1	12	6525-104	3.65
.012 STEEL†	4 x 16	10 x 1-1/8	5	1-3/16	12	6544-065	4.11

† With Scraper

### Small



HANDLE	FILL MATERIAL	NUMBER OF ROWS	BLOCK SIZE	BRUSH PART	TRIM LENGTH	STD. PKG.	ITEM NO.	PRICE EACH
Plastic	.006 SS	3 x 7	7-1/2 x 1/2	1-3/8	1/2	36	6544-075	\$2.82
Wood	.006 SS	3 x 7	7-1/2 x 1/2	1-3/8	1/2	36	6544-167	2.77
Wood	.006 Brass	3 x 7	7-1/2 x 1/2	1-3/8	1/2	36	6544-189	2.89

## Chip and Oil Brushes

### Natural White Bristle Wood Handle



WIDTH	THICKNESS	BRISTLE LENGTH	STD. PKG.	ITEM NO.	PRICE EACH
1/2	5/16	1-3/4	36	6540-065	\$0.49
1	5/16	1-3/4	36	6540-066	0.62
1-1/2	5/16	1-3/4	24	6540-067	0.79
2	5/16	1-3/4	24	6540-068	1.01
2-1/2	3/8	1-3/4	12	6540-069	1.64
3	3/8	1-3/4	12	6540-070	1.68
4	5/8	2	12	6540-071	3.77

## Counter Dusters



FILL MATERIAL	BRUSH LENGTH	TRIM LENGTH	STD. PKG.	ITEM NO.	PRICE EACH
Black Tampico	8	2-1/2	12	6525-251	\$6.27
Black Synthetic	8	2-1/2	12	6525-252	4.99
Black Horsehair	8	2-1/8	12	6544-003	10.21
Grey Tampico	8	2-1/2	12	6544-004	6.03



Black Horsehair

## Parts Cleaning Brush



FILL MATERIAL	DIA.	BRISTLE LENGTH	STD. PKG.	ITEM NO.	PRICE EACH
Nylon	1	2-1/2	12	6525-221	\$2.68
Tampico	1	2-3/4	12	6525-222	2.79

## Tin Handle Acid Brushes

WIDTH	TRIM LENGTH	OVERALL LENGTH	STD. PKG.	ITEM NO.	PRICE EACH
3/8	3/4	5-3/4	144	6544-089	\$0.25
1/2	3/4	5-3/4	144	6544-090	0.29

## Floor Brushes



Fine Sweeping

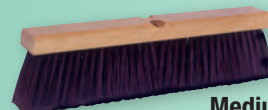

Medium Sweeping



Coarse Sweeping

DESCRIPTION	TRIM LENGTH	STD. PKG.	ITEM NO.	PRICE EACH
<b>Fine Sweeping</b>				
18 Block Black Tampico	2-7/8	1	6525-231	\$11.32
24 Block Black Synthetic	2-7/8	1	6525-232	16.15
<b>Medium Sweeping</b>				
18 Block Synthetic	3	1	6525-234	10.36
24 Block Synthetic	3	1	6525-235	14.45

DESCRIPTION	TRIM LENGTH	STD. PKG.	ITEM NO.	PRICE EACH
<b>Coarse Sweeping</b>				
18 Block Synthetic	3-1/4	1	6525-238	\$10.24
24 Block Synthetic	3-1/4	1	6525-239	15.06
<b>Garage Sweeping</b>				
18 Block Palmyra	4	1	6525-241	9.23
24 Block Palmyra	4	1	6525-242	12.92

## Handles Threaded End - 5" Overall Length

Order No. 6544-018

Price Each .....\$4.83

# Surface Grinding Wheels



2

## Vitrified Bonded for Rich Stock Removal and Excellent Rigidity for Precision Grinding

### WA – White Aluminum Oxide

Friable grain for light grinding of all steels, particularly tool & die steels.

### AZ – Premium Blue Aluminum Oxide

Suitable for HSS grinding on materials 55RC and above. Exceptionally cool, fast cutting.

### CG – Green Silicon Carbide

General purpose grinding on tungsten carbide and non-ferrous metals.

### AS3 – Synthetic Ceramic Blend

Features a blend of synthetic ceramic grain with PA and WA grains for optimum fracturing. Provides a continuous, sharp cutting action.

### 32A – Premium Aluminum Oxide

Outstanding firm holding wheels with free cutting grain, ideal for medium to heavy stock removal. Excellent versatility and performance on a wide range of materials.



**Buy Ctn Qty Deduct 20%**

### RA – Ruby Aluminum Oxide

For fast stock removal on tool steels below 55RC and for high chromium steels. This grain is harder than the PA and AZ.

### 6 x 1/2 x 1-1/4 – No Recess

GRIT/ HARDNESS	MAX RPM	CTN QTY	WHITE ALUMINUM OXIDE (TYPE WA)		PREMIUM BLUE ALUMINUM OXIDE (TYPE AZ)		SILICON CARBIDE (TYPE CG)		SYNTHETIC CERAMIC GRAIN (TYPE AS3)		
			ORDER NO.	PRICE EACH	ORDER NO.	PRICE EACH	ORDER NO.	PRICE EACH	CTN QTY	ORDER NO.	PRICE EACH
60K	4456	10	-	-	3323-024	\$13.35	-	-	-	-	-

### 7 x 1/4 x 1-1/4 – No Recess

GRIT/ HARDNESS	MAX RPM	CTN QTY	WHITE ALUMINUM OXIDE (TYPE WA)		PREMIUM BLUE ALUMINUM OXIDE (TYPE AZ)		SILICON CARBIDE (TYPE CG)		SYNTHETIC CERAMIC GRAIN (TYPE AS3)		
			ORDER NO.	PRICE EACH	ORDER NO.	PRICE EACH	ORDER NO.	PRICE EACH	CTN QTY	ORDER NO.	PRICE EACH
46I	3760	10	3320-102	\$11.50	3323-102	\$11.85	-	-	-	-	-
60I	3760	10	3320-120	11.50	3323-120	11.85	3275-120	\$13.85	-	-	-
60J	3760	10	3320-122	11.50	3323-122	11.85	-	-	-	-	-
60K	3760	10	3320-124	11.50	3323-124	11.85	-	-	10	3326-124	\$22.20
80I	3760	10	-	-	-	-	3275-130	13.85	-	-	-
80J	3760	10	3320-130	11.50	3323-130	11.85	-	-	-	-	-
80K	3760	10	3320-132	11.50	3323-132	11.85	-	-	10	3326-134	22.20
100I	3760	10	-	-	-	-	3275-140	13.85	-	-	-
100K	3760	10	3320-148	11.50	3323-148	11.85	-	-	-	-	-
120K	3760	10	3320-162	11.50	-	-	-	-	-	-	-
150K	3760	10	3320-186	11.50	3323-186	11.85	-	-	-	-	-

† Limited Quantities

### 7 x 1/2 x 1-1/4 – No Recess

GRIT/ HARDNESS	MAX RPM	CTN QTY	WHITE ALUMINUM OXIDE (TYPE WA)		PREMIUM BLUE ALUMINUM OXIDE (TYPE AZ)		GRAY ALUMINUM OXIDE (TYPE 32A)		SILICON CARBIDE (TYPE CG)		SYNTHETIC CERAMIC GRAIN (TYPE AS3)		
			ORDER NO.	PRICE EACH	ORDER NO.	PRICE EACH	ORDER NO.	PRICE EACH	ORDER NO.	PRICE EACH	CTN QTY	ORDER NO.	PRICE EACH
46G	3760	10	3320-300	\$13.70	-	-	-	-	-	-	-	-	-
46H	3760	10	3320-302	13.70	3323-302	\$15.00	3330-302	\$17.10	-	-	10	3326-202	\$29.05
46I	3760	10	3320-304	13.70	3323-304	15.00	3330-304	17.10	-	-	-	-	-
46J	3760	10	3320-306	13.70	3323-306	15.00	3330-306	17.10	-	-	10	3326-204	29.05
46K	3760	10	3320-308	13.70	3323-308	15.00	3330-308	17.10	-	-	-	-	-
60H	3760	10	3320-320	13.70	3323-320	15.00	-	-	-	-	-	-	-
60I	3760	10	3320-322	13.70	3323-322	15.00	3330-322	17.10	3275-320	\$18.90	-	-	-
60J	3760	10	3320-324	13.70	3323-324	15.00	-	-	-	-	-	-	-
60K	3760	10	3320-326	13.70	3323-326	15.00	-	-	-	-	10	3326-224	29.05
60L	3760	10	-	-	3323-328	15.00	-	-	-	-	-	-	-
80H	3760	10	-	-	3323-342	15.00	-	-	-	-	-	-	-
80I	3760	10	-	-	-	-	-	-	3275-330	18.90	-	-	-
80K	3760	10	3320-346	13.70	3323-346	15.00	-	-	-	-	-	-	-
100I	3760	10	-	-	-	-	-	-	3275-340	18.90	-	-	-
100K	3760	10	3320-360	13.70	3323-360	15.00	-	-	-	-	-	-	-
120K	3760	10	3320-374	13.70	3323-374	15.00	-	-	-	-	-	-	-
150K	3760	10	3320-386	13.70	3323-386	15.00	-	-	-	-	-	-	-



# Surface Grinding Wheels



2

Buy  
Ctn Qty  
Deduct  
20%

## Ruby Red Aluminum Oxide

7 x 1/2 x 1-1/4 – No Recess

TYPE RA				
GRIT/ HARDNESS	MAX RPM	CTN QTY	ORDER NO.	PRICE EACH
46H	3600	10	3280-102	\$17.95
46J/K	3600	10	3280-108	17.95
60J/K	3600	10	3280-120	17.95

## 7 x 1/2 x 1-1/4 – Porous Bond – No Recess

			WHITE ALUMINUM OXIDE (TYPE WA)		PREMIUM BLUE ALUMINUM OXIDE (TYPE AZ)		RUBY ALUMINUM OXIDE (TYPE RA)	
GRIT/ HARDNESS	MAX RPM	CTN QTY	ORDER NO.	PRICE EACH	ORDER NO.	PRICE EACH	ORDER NO.	PRICE EACH
46H12	3760	10	3320-402†	\$8.15	3323-402	\$16.50	-	-
46G12	3760	10	-	-	-	-	3277-102	\$20.25
60H12	3760	10	-	-	-	-	3277-108	20.25

† Limited Quantities

## 7 x 3/4 x 1-1/4 – Recessed One Side 3 x 1/4"

			WHITE ALUMINUM OXIDE (TYPE WA)		PREMIUM BLUE ALUMINUM OXIDE (TYPE AZ)		SILICON CARBIDE (TYPE CG)		SYNTHETIC CERAMIC GRAIN (TYPE AS3)		
GRIT/ HARDNESS	MAX RPM	CTN QTY	ORDER NO.	PRICE EACH	ORDER NO.	PRICE EACH	ORDER NO.	PRICE EACH	CTN QTY	ORDER NO.	PRICE EACH
46H	3600	10	3320-500	\$18.65	3323-500	\$20.70	-	-	-	-	-
46I	3600	10	-	-	3323-502	20.70	-	-	-	-	-
46J	3600	10	3320-504	18.65	3323-504	20.70	-	-	-	-	-
46K	3600	10	3320-506†	13.40	3323-506	20.70	-	-	-	-	-
60H	3600	10	3320-518	18.65	3323-518†	11.05	-	-	-	-	-
60I	3600	10	3320-520†	8.65	3323-520†	9.50	3275-520	\$24.25	-	-	-
60J	3600	10	3320-522	18.65	3323-522	20.70	-	-	-	-	-
60K	3600	10	3320-524†	13.45	-	-	-	-	-	-	-
80I	3600	10	-	-	-	-	3275-530	24.25	-	-	-
100I	3600	10	-	-	-	-	3275-540	24.25	-	-	-

† Limited Quantities

## 7 x 1 x 1-1/4 – Recessed One Side 3 x 1/2"

			WHITE ALUMINUM OXIDE (TYPE WA)		PREMIUM BLUE ALUMINUM OXIDE (TYPE AZ)		SILICON CARBIDE (TYPE CG)		SYNTHETIC CERAMIC GRAIN (TYPE AS3)		
GRIT/ HARDNESS	MAX RPM	CTN QTY	ORDER NO.	PRICE EACH	ORDER NO.	PRICE EACH	ORDER NO.	PRICE EACH	CTN QTY	ORDER NO.	PRICE EACH
46H	3600	10	3320-700	\$21.85	3323-700	\$24.80	-	-	-	-	-
46I	3600	10	3320-702	21.85	3323-702	24.80	-	-	-	-	-
46J	3600	10	3320-704	21.85	3323-704	24.80	-	-	-	-	-
46K	3600	10	3320-706	9.50	3323-706	24.80	-	-	-	-	-
60H	3600	10	3320-718†	7.40	-	-	-	-	-	-	-
60I	3600	10	3320-720	21.85	-	-	3275-720	\$28.40	-	-	-
60J	3600	10	3320-722	21.85	3323-722	24.80	-	-	-	-	-
60K	3600	10	-	-	3323-724	24.80	-	-	-	-	-
80I	3600	10	-	-	-	-	3275-730	28.40	-	-	-
100I	3600	10	-	-	-	-	3275-740	28.40	-	-	-

† Limited Quantities

## 8 x 1/4 x 1-1/4 – No Recess

			WHITE ALUMINUM OXIDE (TYPE WA)		PREMIUM BLUE ALUMINUM OXIDE (TYPE AZ)		SILICON CARBIDE (TYPE CG)		SYNTHETIC CERAMIC GRAIN (TYPE AS3)		
GRIT/ HARDNESS	MAX RPM	CTN QTY	ORDER NO.	PRICE EACH	ORDER NO.	PRICE EACH	ORDER NO.	PRICE EACH	CTN QTY	ORDER NO.	PRICE EACH
46H	3600	10	3320-850†	\$8.80	-	-	-	-	-	-	-
46K	3600	10	3320-856†	7.40	-	-	-	-	-	-	-
60K	3600	10	3320-874	15.50	-	-	-	-	-	-	-
80I	3600	10	-	-	-	-	3275-830	\$18.85	-	-	-
80J	3600	10	3320-884	15.50	-	-	-	-	-	-	-

† Limited Quantities

# Surface Grinding Wheels



2



## 8 x 1/2 x 1-1/4 – No Recess

GRIT/ HARDNESS	MAX RPM	CTN QTY	WHITE ALUMINUM OXIDE (TYPE WA)		PREMIUM BLUE ALUMINUM OXIDE (TYPE AZ)		SILICON CARBIDE (TYPE CG)		GREY ALUMINUM OXIDE (TYPE 32A)		SYNTHETIC CERAMIC GRAIN (TYPE AS3)		
			ORDER NO.	PRICE EACH	ORDER NO.	PRICE EACH	ORDER NO.	PRICE EACH	ORDER NO.	PRICE EACH	CTN QTY	ORDER NO.	PRICE EACH
46H	3600	10	3320-900	\$18.80	3323-900	\$19.90	-	-	-	-	-	-	-
46I	3600	10	3320-902	18.80	3323-902	19.90	-	-	3330-902	\$22.20	-	-	-
46J	3600	10	3320-904	18.80	3323-904	19.90	-	-	3330-904	22.20	-	-	-
46K	3600	10	3320-906	18.80	3323-906	19.90	-	-	-	-	10	3326-406	\$40.05
60H	3600	10	-	-	3323-918	19.90	-	-	-	-	-	-	-
60I	3600	10	3320-920	18.80	3323-920	19.90	3275-920	\$25.15	-	-	-	-	-
60J	3600	10	3320-922	18.80	3323-922	19.90	-	-	-	-	10	3326-424	40.05
60K	3600	10	3320-924	18.80	3323-924	19.90	-	-	-	-	-	-	-
80I	3600	10	-	-	-	-	3275-930	25.15	-	-	-	-	-
80K	3600	10	3320-936	18.80	3323-936	19.90	-	-	-	-	-	-	-
100I	3600	10	-	-	-	-	3275-940	25.15	-	-	-	-	-

## 8 x 1/2 x 1-1/4 – Porous Bond - No Recess

RUBY ALUMINUM OXIDE (TYPE RA)				
GRIT/ HARDNESS	MAX RPM	CTN QTY	ORDER NO.	PRICE EACH
46H12	3600	10	3277-133	\$27.90
60H12	3600	10	3277-138	27.90

## 8 x 3/4 x 1-1/4 – Recessed One Side 3 x 1/4"

GRIT/ HARDNESS	MAX RPM	CTN QTY	WHITE ALUMINUM OXIDE (TYPE WA)		PREMIUM BLUE ALUMINUM OXIDE (TYPE AZ)		SILICON CARBIDE (TYPE CG)		SYNTHETIC CERAMIC GRAIN (TYPE AS3)		
			ORDER NO.	PRICE EACH	ORDER NO.	PRICE EACH	ORDER NO.	PRICE EACH	CTN QTY	ORDER NO.	PRICE EACH
46H	3600	10	3321-000	\$25.35	3324-000	\$26.90	-	-	-	-	-
46J	3600	10	3321-004	25.35	3324-004	26.90	-	-	-	-	-
46K	3600	10	3321-006†	10.80	-	-	-	-	-	-	-
60I	3600	10	3321-020	25.35	-	-	3276-020	\$30.50	-	-	-
60J	3600	10	3321-022	25.35	3324-022	26.90	-	-	-	-	-
60K	3600	10	3321-024	25.35	-	-	-	-	-	-	-
80I	3600	10	-	-	-	-	3276-030†	14.05	-	-	-

† Limited Quantities

## 8 x 1 x 1-1/4 – Recessed One Side 3 x 1/2"

GRIT/ HARDNESS	MAX RPM	CTN QTY	WHITE ALUMINUM OXIDE (TYPE WA)		PREMIUM BLUE ALUMINUM OXIDE (TYPE AZ)		SILICON CARBIDE (TYPE CG)		SYNTHETIC CERAMIC GRAIN (TYPE AS3)		
			ORDER NO.	PRICE EACH	ORDER NO.	PRICE EACH	ORDER NO.	PRICE EACH	CTN QTY	ORDER NO.	PRICE EACH
46H	3600	10	3321-100	\$20.45	3324-100	\$30.00	-	-	-	-	-
46I	3600	10	3321-102	29.35	-	-	-	-	-	-	-
46J	3600	10	3321-104	29.35	3324-104	30.00	-	-	-	-	-
46K	3600	10	3321-106	29.35	-	-	-	-	-	-	-
60I	3600	10	3321-120	29.35	-	-	3276-120	\$34.60	-	-	-
60J	3600	10	3321-122	29.35	3324-122	30.00	-	-	-	-	-
60K	3600	10	3321-124	29.35	-	-	-	-	-	-	-
100I	3600	10	-	-	-	-	3276-140	34.60	-	-	-

† Limited Quantities

## 10 x 1/2 x 3 – No Recess

GRIT/ HARDNESS	MAX RPM	CTN QTY	WHITE ALUMINUM OXIDE (TYPE WA)		PREMIUM BLUE ALUMINUM OXIDE (TYPE AZ)		SILICON CARBIDE (TYPE CG)		SYNTHETIC CERAMIC GRAIN (TYPE AS3)		
			ORDER NO.	PRICE EACH	ORDER NO.	PRICE EACH	ORDER NO.	PRICE EACH	CTN QTY	ORDER NO.	PRICE EACH
46J	2630	5	-	-	3324-204†	\$19.10	-	-	-	-	-
60H	2630	5	-	-	3324-218†	19.10	-	-	-	-	-
60J	2630	5	3321-222	\$29.10	-	-	-	-	-	-	-
60K	2630	5	3321-224†	17.35	-	-	-	-	-	-	-

† Limited Quantities

# Surface Grinding Wheels



**Buy  
Ctn Qty  
Deduct  
20%**

2

## 10 x 3/4 x 3 – No Recess

GRIT/ HARDNESS	MAX RPM	CTN QTY	WHITE ALUMINUM OXIDE (TYPE WA)		PREMIUM BLUE ALUMINUM OXIDE (TYPE AZ)		SILICON CARBIDE (TYPE CG)		SYNTHETIC CERAMIC GRAIN (TYPE ASS)		
			ORDER NO.	PRICE EACH	ORDER NO.	PRICE EACH	ORDER NO.	PRICE EACH	CTN QTY	ORDER NO.	PRICE EACH
46I	2630	5	-	-	3324-302	\$38.65	-	-	-	-	-
60H	2630	5	-	-	3324-318	38.65	-	-	-	-	-
60I	2630	5	3321-320	\$37.20	-	-	-	-	-	-	-
60K	2630	5	3321-324†	15.10	-	-	-	-	-	-	-

† Limited Quantities

## 10 x 1 x 3 – No Recess

GRIT/ HARDNESS	MAX RPM	CTN QTY	WHITE ALUMINUM OXIDE (TYPE WA)		PREMIUM BLUE ALUMINUM OXIDE (TYPE AZ)		SILICON CARBIDE (TYPE CG)		SYNTHETIC CERAMIC GRAIN (TYPE ASS)		
			ORDER NO.	PRICE EACH	ORDER NO.	PRICE EACH	ORDER NO.	PRICE EACH	CTN QTY	ORDER NO.	PRICE EACH
46H	2630	5	3321-500	\$44.25	-	-	-	-	-	-	-
46I	2630	5	3321-502	44.25	3324-502	\$45.95	-	-	-	-	-
46J	2630	5	3321-504	44.25	3324-504	45.95	-	-	-	-	-
46K	2630	5	3321-506†	25.25	3324-506	45.95	-	-	3	3326-706	\$94.15
60H	2630	5	-	-	3324-518†	28.60	-	-	-	-	-
60I	2630	5	3321-520†	25.25	3324-520	45.95	-	-	-	-	-
60J	2630	5	3321-522	44.25	3324-522	45.95	-	-	-	-	-
60K	2630	5	3321-524†	25.25	3324-524	45.95	-	-	-	-	-

† Limited Quantities

## 12 x 3/4 x 3 – No Recess

GRIT/ HARDNESS	MAX RPM	CTN QTY	WHITE ALUMINUM OXIDE (TYPE WA)		PREMIUM BLUE ALUMINUM OXIDE (TYPE AZ)		SILICON CARBIDE (TYPE CG)		SYNTHETIC CERAMIC GRAIN (TYPE ASS)		
			ORDER NO.	PRICE EACH	ORDER NO.	PRICE EACH	ORDER NO.	PRICE EACH	CTN QTY	ORDER NO.	PRICE EACH
46H	2228	4	-	-	3324-600	\$50.10	-	-	-	-	-
46I	2228	4	3321-602	\$50.65	-	-	-	-	-	-	-
46K	2228	4	3321-606†	27.20	-	-	-	-	-	-	-

† Limited Quantities

## 12 x 1 x 3 – No Recess

GRIT/ HARDNESS	MAX RPM	CTN QTY	WHITE ALUMINUM OXIDE (TYPE WA)		PREMIUM BLUE ALUMINUM OXIDE (TYPE AZ)		SILICON CARBIDE (TYPE CG)		SYNTHETIC CERAMIC GRAIN (TYPE ASS)		
			ORDER NO.	PRICE EACH	ORDER NO.	PRICE EACH	ORDER NO.	PRICE EACH	CTN QTY	ORDER NO.	PRICE EACH
46H	2228	2	3321-700	\$64.10	3324-700	\$63.40	-	-	2	3326-902	\$137.80
46J	2228	2	3321-704	64.10	3324-704	63.40	-	-	2	3326-904	137.80
46K	2228	2	3321-706†	38.90	3324-706	63.40	-	-	-	-	-
60I	2228	2	-	-	3324-720	63.40	-	-	2	3326-922	137.80
60K	2228	2	-	-	3324-724	63.40	-	-	-	-	-

† Limited Quantities

# Surface Grinding Wheels



**Buy  
Ctn Qty  
Deduct  
20%**

2

## 12 x 1 x 5 – No Recess

GRIT/ HARDNESS	MAX RPM	CTN QTY	WHITE ALUMINUM OXIDE (TYPE WA)		PREMIUM BLUE ALUMINUM OXIDE (TYPE AZ)		SILICON CARBIDE (TYPE CG)		SYNTHETIC CERAMIC GRAIN (TYPE AS3)		
			ORDER NO.	PRICE EACH	ORDER NO.	PRICE EACH	ORDER NO.	PRICE EACH	CTN QTY	ORDER NO.	PRICE EACH
46H	2228	2	3321-800	\$64.10	3324-800	\$63.40	-	-	2	3326-932	\$137.80
46I	2228	2	3321-802†	32.85	-	-	-	-	-	-	-
46J	2228	2	3321-804	64.10	3324-804	63.40	-	-	-	-	-
46K	2228	2	3321-806†	31.80	3324-806	63.40	-	-	-	-	-
60J	2228	2	3321-822	64.10	3324-822	63.40	-	-	-	-	-
60K	2228	2	3321-824	64.10	3324-824	63.40	-	-	-	-	-

† Limited Quantities

## 12 x 1-1/2 x 3 – Recessed One Side 7-1/2 x 1/2"

GRIT/ HARDNESS	MAX RPM	CTN QTY	WHITE ALUMINUM OXIDE (TYPE WA)		PREMIUM BLUE ALUMINUM OXIDE (TYPE AZ)		SILICON CARBIDE (TYPE CG)		SYNTHETIC CERAMIC GRAIN (TYPE AS3)		
			ORDER NO.	PRICE EACH	ORDER NO.	PRICE EACH	ORDER NO.	PRICE EACH	CTN QTY	ORDER NO.	PRICE EACH
46H	2228	2	3321-900	\$91.25	-	-	-	-	-	-	-
46I	2228	2	3321-902	91.25	-	-	-	-	-	-	-
46J	2228	2	3321-904	91.25	-	-	-	-	-	-	-
60I	2228	2	3321-920	91.25	-	-	-	-	-	-	-

## 12 x 1-1/2 x 5 – Recessed One Side 7-1/2 x 1/2"

GRIT/ HARDNESS	MAX RPM	CTN QTY	WHITE ALUMINUM OXIDE (TYPE WA)		PREMIUM BLUE ALUMINUM OXIDE (TYPE AZ)		SILICON CARBIDE (TYPE CG)		SYNTHETIC CERAMIC GRAIN (TYPE AS3)		
			ORDER NO.	PRICE EACH	ORDER NO.	PRICE EACH	ORDER NO.	PRICE EACH	CTN QTY	ORDER NO.	PRICE EACH
46H	2228	2	3322-000	\$91.25	3325-000	\$96.65	-	-	-	-	-
46I	2228	2	3322-002	91.25	-	-	-	-	-	-	-
46J	2228	2	3322-004	91.25	3325-004	96.65	-	-	-	-	-
46K	2228	2	3322-006	91.25	3325-006	96.65	-	-	-	-	-
60I	2228	2	3322-020	91.25	-	-	-	-	-	-	-
60J	2228	2	3322-022	91.25	3325-022	96.65	-	-	-	-	-
60K	2228	2	3322-024	91.25	-	-	-	-	-	-	-

## 12 x 1-1/2 x 5 – Porous Bond – Recessed One Side 7-1/2 x 1/2"

GRIT/ HARDNESS	MAX RPM	CTN QTY	RUBY ALUMINUM OXIDE (TYPE RA)	
			ORDER NO.	PRICE EACH
46H12	2190	2	3277-183	\$138.00

## 12 x 2 x 5 – Recessed Two Sides 7-1/2 x 1/2"

GRIT/ HARDNESS	MAX RPM	CTN QTY	WHITE ALUMINUM OXIDE (TYPE WA)		PREMIUM BLUE ALUMINUM OXIDE (TYPE AZ)		SILICON CARBIDE (TYPE CG)		SYNTHETIC CERAMIC GRAIN (TYPE AS3)		
			ORDER NO.	PRICE EACH	ORDER NO.	PRICE EACH	ORDER NO.	PRICE EACH	CTN QTY	ORDER NO.	PRICE EACH
46H	2228	2	-	-	3325-100	\$112.65	-	-	-	-	-
46I	2228	2	3322-102	\$105.35	3325-102	112.65	-	-	-	-	-
46J	2228	2	3322-104	105.35	-	-	-	-	-	-	-
60H	2228	2	3322-118	105.35	3325-118	112.65	-	-	-	-	-

# Surface Grinding Wheels



2

**Buy  
Ctn Qty  
Deduct  
20%**

## 14 x 1 x 5 – No Recess

GRIT/ HARDNESS	MAX RPM	CTN QTY	WHITE ALUMINUM OXIDE (TYPE WA)		PREMIUM BLUE ALUMINUM OXIDE (TYPE AZ)		GREY ALUMINUM OXIDE (TYPE 32A)		SYNTHETIC CERAMIC GRAIN (TYPE AS3)		
			ORDER NO.	PRICE EACH	ORDER NO.	PRICE EACH	ORDER NO.	PRICE EACH	CTN QTY	ORDER NO.	PRICE EACH
46H	1910	2	-	-	3325-200	\$103.95	3332-200	\$113.35	-	-	-
46I	1910	2	3322-202	\$89.90	3325-202	103.95	3332-202	113.35	-	-	-
46J	1910	2	-	-	3325-204	103.95	-	-	2	3326-954	\$170.65
60I	1910	2	3322-220	89.90	3325-220	103.95	-	-	-	-	-
60K	1880	2	3322-224	89.90	3325-224	103.95	-	-	-	-	-

## 14 x 1-1/2 x 5 – No Recess

GRIT/ HARDNESS	MAX RPM	CTN QTY	WHITE ALUMINUM OXIDE (TYPE WA)		PREMIUM BLUE ALUMINUM OXIDE (TYPE AZ)		GRAY ALUMINUM OXIDE (TYPE 32A)	
			ORDER NO.	PRICE EACH	ORDER NO.	PRICE EACH	ORDER NO.	PRICE EACH
46H	1910	2	3322-250	\$120.50	3325-250	\$139.40	3332-250	\$149.20
46I	1910	2	3322-252	120.50	-	-	3332-254	149.20
46J	1910	2	3322-254	120.50	3325-254	139.40	-	-
46K	1910	2	-	-	3325-256	139.40	-	-
60H	1910	2	-	-	3325-268	139.40	-	-
60J	1910	2	-	-	3325-272	139.40	-	-

## 14 x 1-1/2 x 5 Porous Bond – No Recess

RUBY ALUMINUM OXIDE (TYPE RA)				
GRIT/ HARDNESS	MAX RPM	CTN QTY	ORDER NO.	PRICE EACH
46H12	1910	2	3277-243	\$171.25

## 14 x 1-1/2 x 5 – Recessed One Side 8 x 1/2"

GRIT/ HARDNESS	MAX RPM	CTN QTY	WHITE ALUMINUM OXIDE (TYPE WA)		PREMIUM BLUE ALUMINUM OXIDE (TYPE AZ)		SYNTHETIC CERAMIC GRAIN (TYPE AS3)	
			ORDER NO.	PRICE EACH	ORDER NO.	PRICE EACH	ORDER NO.	PRICE EACH
46H	1910	2	3322-300	\$120.50	3325-300	\$139.40	-	-
46I	1910	2	3322-302	120.50	3325-302	139.40	-	-
46J	1910	2	3322-304	120.50	3325-304	139.40	-	-
60H	1910	2	3322-318	120.50	-	-	-	-
60I	1910	2	3322-320	120.50	3325-320	139.40	3326-966	\$260.55
60J	1910	2	-	-	3325-322	139.40	-	-

## 14 x 1-1/2 x 5 - Porous Bond Recessed One Side 8 x 1/2"

RUBY ALUMINUM OXIDE (TYPE RA)				
GRIT/ HARDNESS	MAX RPM	CTN QTY	ORDER NO.	PRICE EACH
46H12	1910	2	3277-253	\$178.65

## 14 x 2 x 5 – Recessed One Side 8 x 1"

GRIT/ HARDNESS	MAX RPM	CTN QTY	WHITE ALUMINUM OXIDE (TYPE WA)		PREMIUM BLUE ALUMINUM OXIDE (TYPE AZ)		SILICON CARBIDE (TYPE CG)		SYNTHETIC CERAMIC GRAIN (TYPE AS3)		
			ORDER NO.	PRICE EACH	ORDER NO.	PRICE EACH	ORDER NO.	PRICE EACH	CTN QTY	ORDER NO.	PRICE EACH
46H	1910	1	3322-400	\$122.40	3325-400	\$141.55	-	-	-	-	-
46I	1910	1	3322-402	122.40	3325-402	141.55	-	-	-	-	-
46J	1910	1	3322-404	122.40	3325-404	141.55	-	-	-	-	-
46K	1910	1	3322-406	122.40	-	-	-	-	-	-	-
60I	1910	1	3322-420	122.40	-	-	-	-	-	-	-
60J	1910	1	3322-422	122.40	3325-422	141.55	-	-	-	-	-
60K	1910	1	-	-	3325-424	141.55	-	-	-	-	-

\*Carton Qty. deduction not applicable

## 14 x 2 x 5 - Porous Bond – Recessed One Side 8 x 1"

RUBY ALUMINUM OXIDE (TYPE RA)				
GRIT/ HARDNESS	MAX RPM	CTN QTY	ORDER NO.	PRICE EACH
46H12	1880	1	3277-273	\$171.10

\*Carton Qty. deduction not applicable

# Tool & Cutter Grinding Wheels



**Buy  
Ctn Qty  
Deduct  
20%**

**Vitrified Bonded Assortment of the Standard Shapes Most Commonly Used in Tool and Cutter Applications.**

**WA – White Aluminum Oxide**  
Friable grain for light grinding of all steels, particularly tool & die steels.

**CG – Green Silicon Carbide**  
Used for non-ferrous metals such as cemented carbides.

**AS3 – Synthetic Ceramic Blend**  
Features a blend of synthetic ceramic grain with PA and WA grains for optimum fracturing. Provides a continuous, sharp cutting action.

## 4/3 x 1-1/2 x 1-1/4 – Flaring Cup Wheel

GRIT/ HARDNESS	MAX RPM	CTN QTY	WHITE ALUMINUM OXIDE (TYPE WA)		SILICON CARBIDE (TYPE CG)		SYNTHETIC CERAMIC GRAIN (TYPE AS3)		
			ORDER NO.	PRICE EACH	ORDER NO.	PRICE EACH	CTN QTY	ORDER NO.	PRICE EACH
46I	6685	10	3102-732†	\$7.40	–	–	3	3103-820	\$34.90
46J	6685	10	3102-733	16.65	–	–	–	–	–
46K	6685	10	3102-734	16.65	–	–	–	–	–
60H	6685	10	3102-741†	10.40	–	–	–	–	–
60I	6685	10	3102-742	16.65	–	–	–	–	–
60J	6685	10	3102-743	16.65	–	–	–	–	–
60K	6685	10	3102-744	16.65	–	–	3	3103-830	34.90
80K	6685	10	3102-750	16.65	–	–	–	–	–

† Limited Quantities



## 5/3-3/4 x 1-3/4 x 1-1/4 – Flaring Cup Wheel

GRIT/ HARDNESS	MAX RPM	CTN QTY	WHITE ALUMINUM OXIDE (TYPE WA)		SILICON CARBIDE (TYPE CG)		SYNTHETIC CERAMIC GRAIN (TYPE AS3)		
			ORDER NO.	PRICE EACH	ORDER NO.	PRICE EACH	CTN QTY	ORDER NO.	PRICE EACH
46H	5348	10	3102-802	\$24.90	–	–	–	–	–
46I	5348	10	3102-805	24.90	–	–	3	3103-880	\$46.25
46J	5348	10	3102-803	24.90	–	–	–	–	–
46K	5348	10	3102-804	24.90	–	–	–	–	–
60I	5348	10	3102-815	24.90	3103-120	\$30.55	–	–	–
60J	5348	10	3102-813	24.90	–	–	3	3103-890	46.25
60K	5348	10	3102-814	24.90	–	–	–	–	–
80K	5348	10	3102-820	24.90	–	–	–	–	–



## 5 x 1-1/2 x 1-1/4 – Straight Cup Wheel

GRIT/ HARDNESS	MAX RPM	CTN QTY	WHITE ALUMINUM OXIDE (TYPE WA)		SILICON CARBIDE (TYPE CG)		SYNTHETIC CERAMIC GRAIN (TYPE AS3)		
			ORDER NO.	PRICE EACH	ORDER NO.	PRICE EACH	CTN QTY	ORDER NO.	PRICE EACH
46J	5348	10	3102-853	\$22.85	–	–	–	–	–
46K	5348	10	3102-854	22.85	–	–	–	–	–
60I	5348	10	–	–	3103-220†	\$11.85	–	–	–
60J	5348	10	3102-863	22.85	–	–	–	–	–
60K	5348	10	3102-864	22.85	–	–	–	–	–
80K	5348	10	3102-870	22.85	–	–	–	–	–

† Limited Quantities



# Tool & Cutter Grinding Wheels



**Buy  
Ctn Qty  
Deduct  
20%**

## Vitrified Bonded Assortment of the Standard Shapes Most Commonly Used in Tool and Cutter Applications.

2

**WA – White Aluminum Oxide**  
Friable grain for light grinding of all steels, particularly tool & die steels.

**CG – Green Silicon Carbide**  
Used for non-ferrous metals such as cemented carbides.

**AS3 – Synthetic Ceramic Blend**  
Features a blend of synthetic ceramic grain with PA and WA grains for optimum fracturing. Provides a continuous, sharp cutting action.

### 6 x 1/2 x 1-1/4 – Dish Wheel

GRIT/ HARDNESS	MAX RPM	CTN QTY	WHITE ALUMINUM OXIDE (TYPE WA)		SILICON CARBIDE (TYPE CG)		SYNTHETIC CERAMIC GRAIN (TYPE AS3)		
			ORDER NO.	PRICE EACH	ORDER NO.	PRICE EACH	CTN QTY	ORDER NO.	PRICE EACH
46K	4456	10	3102-914	\$16.05	-	-	-	-	-
60J	4456	10	3102-923	16.05	-	-	-	-	-
60K	4456	10	3102-924	16.05	-	-	-	-	-



### 6 x 1 x 4 – Plate Mounted Wheels

GRIT/ HARDNESS	MAX RPM	CTN QTY	WHITE ALUMINUM OXIDE (TYPE WA)		SILICON CARBIDE (TYPE CG)		SYNTHETIC CERAMIC GRAIN (TYPE AS3)		
			ORDER NO.	PRICE EACH	ORDER NO.	PRICE EACH	CTN QTY	ORDER NO.	PRICE EACH
46K	3450	10	3103-960	\$40.30	-	-	-	-	-
60I	3450	10	-	-	3103-920	\$43.40	-	-	-
80I	3450	10	-	-	3103-930	43.40	-	-	-
100I	3450	10	-	-	3103-940	43.40	-	-	-
120I	3450	10	-	-	3103-950	43.40	-	-	-

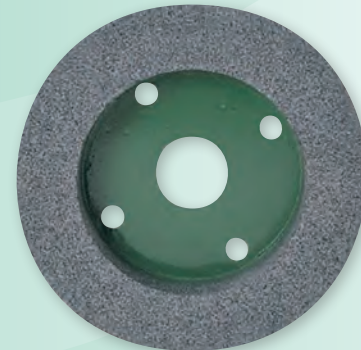

## Vitrified Bond Silicon Carbide Dressing Sticks

For cleaning, dressing and reshaping vitrified bond grinding wheels.

SIZE	GRADE	ORDER NO.	PRICE EACH
6 x 1 x 1	24S	3132-998	\$2.21
8 x 1 x 1	24S	3132-999	2.81

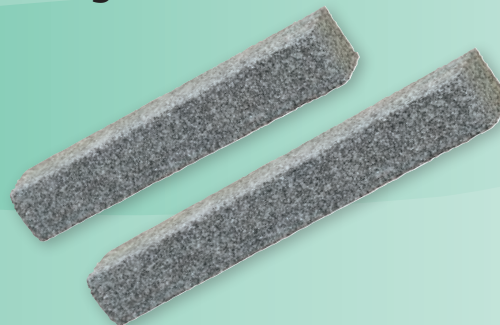

# Bench and Pedestal Wheels



2

**Vitrified Bonded Straight Wheels Used for Off-hand Tool Sharpening and General Purpose Bench Grinding Applications.**

**Buy Ctn Qty Deduct 20%**



## A – Dark Aluminum Oxide

The most common of all grains. This grain is used for heavy duty general purpose work.

## CG – Green Silicon Carbide

Used for non-ferrous metals such as cemented carbides.

### 6 x 1/2 x H (Telescopic Bushing 3/4, 5/8, 1/2")

GRIT/ HARDNESS	MAX RPM	CTN QTY	DARK ALUMINUM OXIDE (TYPE A)		SILICON CARBIDE (TYPE CG)	
			ORDER NO.	PRICE EACH	ORDER NO.	PRICE EACH
24Q	4138	10	3102-001	\$14.45	-	-
360	4138	10	3102-002†	4.65	-	-
46M	4138	10	3102-003	14.45	-	-
60I	4138	10	-	-	3102-402	\$13.70
60M	4138	10	3102-004	14.45	-	-
80I	4138	10	-	-	3102-404	13.70
80M	4138	10	3102-005	14.45	-	-
100I	4138	10	-	-	3102-406	13.70

† Limited Quantities

### 6 x 3/4 x H (Telescopic Bushing 3/4, 5/8, 1/2")

GRIT/ HARDNESS	MAX RPM	CTN QTY	DARK ALUMINUM OXIDE (TYPE A)		SILICON CARBIDE (TYPE CG)	
			ORDER NO.	PRICE EACH	ORDER NO.	PRICE EACH
24Q	4138	10	3102-021	\$12.45	-	-
360	4138	10	3102-022	12.45	-	-
46M	4138	10	3102-023	12.45	-	-
60I	4138	10	-	-	3102-422	\$16.20
60M	4138	10	3102-024	12.45	-	-
80I	4138	10	-	-	3102-424	16.20
80M	4138	10	3102-025	12.45	-	-
100I	4138	10	-	-	3102-426	16.20

### 6 x 1 x H (Telescopic Bushing 3/4, 5/8, 1/2")

GRIT/ HARDNESS	MAX RPM	CTN QTY	DARK ALUMINUM OXIDE (TYPE A)		SILICON CARBIDE (TYPE CG)	
			ORDER NO.	PRICE EACH	ORDER NO.	PRICE EACH
24Q	4138	10	3102-041	\$14.35	-	-
360	4138	10	3102-042	14.35	-	-
46M	4138	10	3102-043	14.35	-	-
60I	4138	10	-	-	3102-442	\$17.90
60M	4138	10	3102-044	14.35	-	-
80I	4138	10	-	-	3102-444	17.90
80M	4138	10	3102-045	14.35	-	-
100I	4138	10	-	-	3102-446	17.90

GRIT/ HARDNESS	MAX RPM	CTN QTY	DARK ALUMINUM OXIDE (TYPE A)		SILICON CARBIDE (TYPE CG)	
			ORDER NO.	PRICE EACH	ORDER NO.	PRICE EACH
24Q	3600	10	3102-061†	\$7.75	-	-
360	3600	10	3102-062†	7.10	-	-
60I	3600	10	-	-	3102-462	\$18.45
60M	3600	10	3102-064	19.45	-	-
80I	3600	10	-	-	3102-464	18.45
100I	3600	10	-	-	3102-466	18.45

† Limited Quantities

### 7 x 1 x H (Telescopic Bushing 3/4, 5/8, 1/2")

GRIT/ HARDNESS	MAX RPM	CTN QTY	DARK ALUMINUM OXIDE (TYPE A)		SILICON CARBIDE (TYPE CG)	
			ORDER NO.	PRICE EACH	ORDER NO.	PRICE EACH
24Q	3600	10	3102-081	\$17.00	-	-
360	3600	10	3102-082	17.00	-	-
46M	3600	10	3102-083	17.00	-	-
60I	3600	10	-	-	3102-482	\$21.75
60M	3600	10	3102-084	17.00	-	-
80I	3600	10	-	-	3102-484	21.75
80M	3600	10	3102-085	17.00	-	-
100I	3600	10	-	-	3102-486	21.75

### 8 x 1 x H (Telescopic Bushing 3/4, 5/8, 1/2")

GRIT/ HARDNESS	MAX RPM	CTN QTY	DARK ALUMINUM OXIDE (TYPE A)		SILICON CARBIDE (TYPE CG)	
			ORDER NO.	PRICE EACH	ORDER NO.	PRICE EACH
24Q	3600	10	3102-105	\$21.70	-	-
360	3600	10	3102-106	21.70	-	-
46M	3600	10	3102-107	21.70	-	-
60I	3600	10	-	-	3102-522	\$26.80
60M	3600	10	3102-108	21.70	-	-
80I	3600	10	-	-	3102-524	26.80
80M	3600	10	3102-109	21.70	-	-
100I	3600	10	-	-	3102-526	26.80

### 10 x 1 x 1-1/4"

GRIT/ HARDNESS	MAX RPM	CTN QTY	DARK ALUMINUM OXIDE (TYPE A)		SILICON CARBIDE (TYPE CG)	
			ORDER NO.	PRICE EACH	ORDER NO.	PRICE EACH
24Q	2483	5	3102-141	\$42.60	-	-
360	2483	5	3102-142	42.60	-	-
46M	2483	5	3102-143	42.60	-	-
60I	2483	5	-	-	3102-542	\$54.80
60M	2483	5	3102-144	42.60	-	-
80I	2483	5	-	-	3102-544	54.80
80M	2483	5	3102-145	42.60	-	-
100I	2483	5	-	-	3102-546	54.80

### 10 x 1-1/2 x 1-1/4"

GRIT/ HARDNESS	MAX RPM	CTN QTY	DARK ALUMINUM OXIDE (TYPE A)		SILICON CARBIDE (TYPE CG)	
			ORDER NO.	PRICE EACH	ORDER NO.	PRICE EACH
24Q	2483	4	3102-161	\$54.75	-	-
360	2483	4	3102-162	54.75	-	-
46M	2483	4	3102-163	54.75	-	-
60I	2483	4	-	-	3102-562	\$63.55
60M	2483	4	3102-164	54.75	-	-
80I	2483	4	-	-	3102-564	63.55
80M	2483	4	3102-165	54.75	-	-
100I	2483	4	-	-	3102-566	63.55



# Bench and Pedestal Wheels



**Vitrified Bonded Straight Wheels  
Used for Off-hand Tool Sharpening and  
General Purpose Bench Grinding Applications**



2

**Buy  
Ctn Qty  
Deduct 20%  
except 16"  
and 18"  
Diameters**

## 12 x 1 x 1-1/4"

GRIT/ HARDNESS	MAX RPM	CTN QTY	DARK ALUMINUM OXIDE (TYPE WA)		SILICON CARBIDE (TYPE CG)	
			ORDER NO.	PRICE EACH	ORDER NO.	PRICE EACH
24Q	2069	2	3102-181	\$66.90	-	-
46M	2069	2	3102-183	66.90	-	-
60I	2069	2	-	-	3102-582	\$75.60
60M	2069	2	3102-184	66.90	-	-

## 12 x 1-1/2 x 1-1/4"

GRIT/ HARDNESS	MAX RPM	CTN QTY	DARK ALUMINUM OXIDE (TYPE WA)		SILICON CARBIDE (TYPE CG)	
			ORDER NO.	PRICE EACH	ORDER NO.	PRICE EACH
24Q	2069	2	3102-205	\$83.85	-	-
360	2069	2	3102-206	83.85	-	-
46M	2069	2	3102-207	83.85	-	-
60I	2069	2	-	-	3102-602	\$96.45
60M	2069	2	3102-208	83.85	-	-
80I	2069	2	-	-	3102-604	96.45

## 12 x 2 x 1-1/2"

GRIT/ HARDNESS	MAX RPM	CTN QTY	DARK ALUMINUM OXIDE (TYPE WA)		SILICON CARBIDE (TYPE CG)	
			ORDER NO.	PRICE EACH	ORDER NO.	PRICE EACH
24Q	2069	2	3102-221	\$90.60	-	-
360	2069	2	3102-222	90.60	-	-
46M	2069	2	3102-223	90.60	-	-
60I	2069	2	-	-	3102-622	\$108.50
60M	2069	2	3102-224	90.60	-	-
80I	2069	2	-	-	3102-624	108.50
80M	2069	2	3102-225	90.60	-	-
100I	2069	2	-	-	3102-626	108.50

## 14 x 2 x 1-1/4" To 1-1/2"

GRIT/ HARDNESS	MAX RPM	CTN QTY	DARK ALUMINUM OXIDE (TYPE WA)		SILICON CARBIDE (TYPE CG)	
			ORDER NO.	PRICE EACH	ORDER NO.	PRICE EACH
24Q	2069	2	3102-271	\$141.70	-	-
360	2069	2	3102-272	141.70	-	-
46M	2069	2	3102-273	141.70	-	-
60I	2069	2	-	-	3102-642	\$180.85
60M	2069	2	3102-274	141.70	-	-
80I	2069	2	-	-	3102-644	180.85
80M	2069	2	3102-275	141.70	-	-

## 16 x 2 x 1-1/2"

GRIT/ HARDNESS	MAX RPM	CTN QTY	DARK ALUMINUM OXIDE (TYPE WA)		SILICON CARBIDE (TYPE CG)	
			ORDER NO.	PRICE EACH	ORDER NO.	PRICE EACH
24Q	1550	1	3102-301	\$187.70	-	-
360	1550	1	3102-302	187.70	-	-

Carton quantity discount does not apply

## 18 x 3 x 1-1/2"

GRIT/ HARDNESS	MAX RPM	CTN QTY	DARK ALUMINUM OXIDE (TYPE WA)		SILICON CARBIDE (TYPE CG)	
			ORDER NO.	PRICE EACH	ORDER NO.	PRICE EACH
24Q	1379	1	3102-321	\$298.35	-	-
360	1379	1	3102-322	298.35	-	-
54M	1379	1	3102-324	298.35	-	-

Carton quantity discount does not apply

# Mattison-Thompson Type



## Large 20 Inch Diameter Surface Grinding Wheels For Horizontal Spindle, Rotary and Reciprocating Tables.

### 83A – Friable Full Premium Aluminum Oxide

Friable grain for fast stock removal.  
The free cutting open structure is ideal for all tool steels.  
V-18 – Normal structures. V-18P – Induced open porosity.

### 73C – Silicon Carbide

For non-ferrous metals, gray iron.

### 91A – Semi-Friable, Mixed Aluminum Oxide

Provides a continuous, sharp cutting action. A mixture of WA and A abrasives.  
Recommended for general purpose work and light stock removal.

### AS3 – Synthetic Ceramic Blend

Features a blend of synthetic ceramic grain with PA and WA grains for optimum fracturing.



1

**Buy Ctn Qty (Where shown) Deduct 10%**

### 20 x 1 x 8

GRAIN	GRIT/ BOND	MAX RPM	ORDER NO.	PRICE EACH
83A	46H8 V-18	1241	3280-402*	\$133.65
83A	60J8 V-18	1241	3280-404*	133.65

\*CARTON QTY.= 3

### 20 x 1 x 10

GRAIN	GRIT/ BOND	MAX RPM	ORDER NO.	PRICE EACH
83A	36J8 V-18	1241	3280-410*	\$ 127.25

\*CARTON QTY.= 3

### 20 x 1-1/2 x 8

Recessed 1/5 11-1/2 x 1/2"

GRAIN	GRIT/ BOND	MAX RPM	ORDER NO.	PRICE EACH
83A	46H8 V-18	1241	3280-422*	\$180.70
83A	60J8 V-18	1241	3280-424*	180.70

\*CARTON QTY.= 2

### 20 x 1-1/2 x 10

GRAIN	GRIT/ BOND	MAX RPM	ORDER NO.	PRICE EACH
83A	46H8 V-18	1241	3280-432*	\$163.65

\*CARTON QTY.= 2

### 20 x 2 x 8

Recessed 2/5 11-1/2 x 1/2"

GRAIN	GRIT/ BOND	MAX RPM	ORDER NO.	PRICE EACH
83A	46H8 V-18	1241	3280-442*	\$224.55
83A	60J8 V-18	1241	3280-446*	224.55
83A	36J/K V-18P	1241	3280-448*	224.55
83A	46G+ V-18P	1241	3280-449*	224.55
91A	46I8 V-18	1241	3280-440*	220.00

\*CARTON QTY.= 2

### 20 x 2 x 10

GRAIN	GRIT/ BOND	MAX RPM	ORDER NO.	PRICE EACH
83A	36J8 V-18	1241	3280-450*	\$202.75
83A	46H8 V-18	1241	3280-452*	202.75
83A	60J8 V-18	1241	3280-454*	202.75
83A	46G+ V-18P	1241	3280-456*	202.75

\*CARTON QTY.= 2

### 20 x 3 x 8

Recessed 2/5 11-1/2 x 1/2"

GRAIN	GRIT/ BOND	MAX RPM	ORDER NO.	PRICE EACH
83A	46H8 V-18	1241	3280-462*	\$310.60
83A	36J/K V-18P	1241	3280-464*	310.60
83A	46D V-18P	1241	3280-465*	310.60
83A	46G+ V-18P	1241	3280-466*	310.60
91A	46I8 V-18	1241	3280-460*	303.45
73C	46I8 V-X	1241	3280-606*	413.55

\*CARTON QTY.= 2

### 20 x 3 x 10

Recessed 1/5 12-1/2 x 5/8"

O/S 12-1/2 x 1"

GRAIN	GRIT/ BOND	MAX RPM	ORDER NO.	PRICE EACH
83A	46H8 V-18	1241	3280-472*	\$276.70
83A	60J8 V-18	1241	3280-473*	276.70
83A	36J/K V-18P	1241	3280-474*	276.70
83A	46D V-18P	1241	3280-476*	276.70
83A	46G+ V-18P	1241	3280-478*	276.70
91A	46I8 V-18	1241	3280-470*	276.70
73C	46I8 V-X	1241	3280-608*	367.45
AS3	46H V-CER	1241	3280-664*	542.55

\*CARTON QTY.= 2

### 20 x 4 x 8

Recessed 2/5 11-1/2 x 1/2"

GRAIN	GRIT/ BOND	MAX RPM	ORDER NO.	PRICE EACH
83A	46H8 V-18	1241	3280-482	\$366.10
83A	36J/K V-18P	1241	3280-484	366.10
83A	46G+ V-18P	1241	3280-488	366.10

### 20 x 4 x 10

Recessed 1/5 12-1/2 x 7/8"

O/S 12-1/2 x 1-1/4"

GRAIN	GRIT/ BOND	MAX RPM	ORDER NO.	PRICE EACH
83A	46H8 V-18	1241	3280-492	\$330.30
83A	36J/K V-18P	1241	3280-494	330.30
83A	46G+ V-18P	1241	3280-498	330.30
91A	46I8 V-18	1241	3280-490	307.95

### 20 x 6 x 10

Recessed 1/5 12-1/2 x 1"

O/S 12-1/2 x 2"

GRAIN	GRIT/ BOND	MAX RPM	ORDER NO.	PRICE EACH
83A	46H8 V-18	1241	3280-502	\$423.20
83A	36J/K V-18P	1241	3280-504	423.20
83A	46G+ V-18P	1241	3280-508	410.85
91A	46I8 V-18	1241	3280-500	403.05
73C	46I8 V-X	1241	3280-614	620.80
AS3	46H V-CER	1241	3280-674	782.55

### 20 x 6 x 12

Recessed 2/5 14-1/4 x 1"

GRAIN	GRIT/ BOND	MAX RPM	ORDER NO.	PRICE EACH
83A	46H8 V-18	1241	3280-512	\$436.70
83A	36J/K V-18P	1241	3280-514	436.70
83A	46G+ V-18P	1241	3280-518	436.70
91A	46I8 V-18	1241	3280-510	425.20

### 20 x 8 x 12

Recessed 2/5 14-1/2 x 1"

GRAIN	GRIT/ BOND	MAX RPM	ORDER NO.	PRICE EACH
83A	46H8 V-18	1241	3280-522	\$506.10

# Centerless & Cylindrical Wheels

## 12" Through 24" Diameter

Centerless & Cylindrical Wheels each have accurate toleranced inside linings to protect spindles. Manufactured with varying hardness to assure consistent grindability throughout.



1

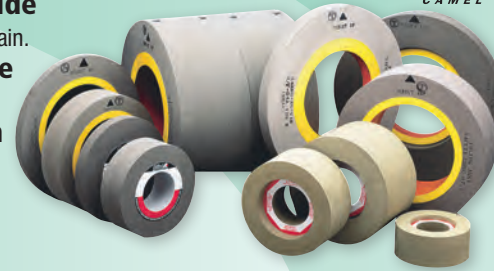

**Buy Ctn Qty (Where shown) Deduct 10%**

### 94A – Aluminum Oxide

Very durable self-dressing grain.

### 72C – Silicon Carbide

For non-ferrous metals.

### PA – Pink Aluminum Oxide

Excellent for pre-hardened carbon steels.

### 12 x 4 x 5 – No Recess

GRAIN	GRIT	MAX RPM	ORDER NO.	PRICE EACH
94A	60-L	2228	3327-006	\$140.25

### 14 x 1 x 5 – No Recess

GRAIN	GRIT	MAX RPM	ORDER NO.	PRICE EACH
94A	54-K	1910	3327-012*	\$60.00
94A	60-L	1910	3327-016*	60.00
94A	80-M	1910	3327-020*	60.00

\*CARTON QTY.= 2

### 14 x 1-1/4 x 5 – No Recess

GRAIN	GRIT	MAX RPM	ORDER NO.	PRICE EACH
94A	54-K	1910	3327-032*	\$75.10
94A	60-L	1910	3327-036*	75.10

\*CARTON QTY.= 2

### 14 x 1-1/2 x 5 – Rec 1/8 X 1/2"

GRAIN	GRIT	MAX RPM	ORDER NO.	PRICE EACH
94A	54-K	1910	3327-052*	\$91.75
94A	60-L	1910	3327-056*	91.75
94A	80-M	1910	3327-060*	91.75

\*CARTON QTY.= 2

### 14 x 2 x 5 – Rec 1/8 X 1"

GRAIN	GRIT	MAX RPM	ORDER NO.	PRICE EACH
94A	54-K	1910	3327-072	\$103.90
94A	60-L	1910	3327-076	103.90
94A	80-M	1910	3327-080	103.90

### 16 x 1 x 5 – No Recess

GRAIN	GRIT	MAX RPM	ORDER NO.	PRICE EACH
94A	60-L	1671	3327-096	\$77.50
94A	80-M	1671	3327-100	77.50

### 16 x 1-1/2 x 5 – No Recess

GRAIN	GRIT	MAX RPM	ORDER NO.	PRICE EACH
94A	60-L	1671	3327-116	\$95.95
94A	80-M	1671	3327-120	95.95

### 16 x 2 x 5 – No Recess

GRAIN	GRIT	MAX RPM	ORDER NO.	PRICE EACH
94A	60-L	1671	3327-156	\$118.15
94A	80-M	1671	3327-160	118.15

### 16 x 1 x 8 – No Recess

GRAIN	GRIT	MAX RPM	ORDER NO.	PRICE EACH
94A	54-K	1671	3327-192	\$74.45
94A	60-L	1671	3327-196	74.45
94A	80-M	1671	3327-200	74.45

### 16 x 1-1/2 x 8 – No Recess

GRAIN	GRIT	MAX RPM	ORDER NO.	PRICE EACH
94A	54-K	1671	3327-212	\$92.25
94A	60-L	1671	3327-216	92.25
94A	80-M	1671	3327-220	92.25

### 16 x 2 x 8 – No Recess

GRAIN	GRIT	MAX RPM	ORDER NO.	PRICE EACH
94A	54-K5	1671	3327-232	\$111.40
94A	60-L5	1671	3327-236	111.40

### 16 x 4 x 10 – No Recess

GRAIN	GRIT	MAX RPM	ORDER NO.	PRICE EACH
94A	60-L	1671	3327-256	\$193.35
94A	80-L	1671	3327-260	193.35

### 20 x 1 x 12 – No Recess

GRAIN	GRIT	MAX RPM	ORDER NO.	PRICE EACH
94A	60-K	1623	3327-276*	\$105.05
94A	60-L	1623	3327-278*	105.05
94A	60-M	1623	3327-280*	105.05
94A	80-O	1623	3327-304*	105.05

\*CARTON QTY.= 3

### 20 x 2 x 12 – No Recess

GRAIN	GRIT	MAX RPM	ORDER NO.	PRICE EACH
94A	60-K	1623	3327-316*	\$164.70
94A	60-L	1623	3327-318*	164.70
94A	60-M	1623	3327-320*	164.70
94A	80-M	1623	3327-326*	164.70
94A	80-O	1623	3327-334*	164.70
94A	80-P	1623	3327-336*	164.70

#### HARD SIDE

94A	80-N/120-S	1623	3327-330*	178.00
-----	------------	------	-----------	--------

\*CARTON QTY.= 2

### 20 x 2-1/2 x 12 – No Recess

GRAIN	GRIT	MAX RPM	ORDER NO.	PRICE EACH
HARD SIDE				
94A	80-N/120-S	1623	3327-360*	\$222.15

\*CARTON QTY.= 2

### 20 x 3 x 12 – No Recess

GRAIN	GRIT	MAX RPM	ORDER NO.	PRICE EACH
94A	60-K	1623	3327-376*	\$231.00
94A	60-L	1623	3327-378*	231.00

\*CARTON QTY.= 2

### 20 x 4 x 12 – No Recess

GRAIN	GRIT	MAX RPM	ORDER NO.	PRICE EACH
94A	60-K	1623	3327-436	\$260.85
94A	60-L	1623	3327-438	260.85
94A	60-M	1623	3327-440	260.85
94A	80-M	1623	3327-448	260.85
94A	80-P	1623	3327-458	260.85

#### HARD SIDE

94A	80-N/120-S	1623	3327-452	281.95
-----	------------	------	----------	--------

### 20 x 6 x 12 – No Recess

GRAIN	GRIT	MAX RPM	ORDER NO.	PRICE EACH
72C	60-L	1623	3327-470	\$484.05
94A	60-K	1623	3327-476	357.60
94A	60-L	1623	3327-478	357.60
94A	60-M	1623	3327-480	357.60
94A	80-J	1623	3327-484	357.60
94A	80-L	1623	3327-486	357.60
94A	80-M	1623	3327-488	357.60
94A	80-O	1623	3327-496	357.60
94A	80-P	1623	3327-498	357.60

#### HARD SIDE

94A	80-N/120-S	1623	3327-492	398.10
-----	------------	------	----------	--------

### 20 x 8 x 12 – No Recess

GRAIN	GRIT	MAX RPM	ORDER NO.	PRICE EACH
72C	60-L	1623	3327-510	\$589.15
94A	54-J	1623	3327-512	459.50
94A	60-K	1623	3327-516	459.50
94A	60-L	1623	3327-518	459.50
94A	60-M	1623	3327-520	459.50
94A	80-J	1623	3327-524	459.50
94A	80-L	1623	3327-526	459.50
94A	80-M	1623	3327-528	459.50
94A	80-O	1623	3327-536	459.50

#### HARD SIDE

94A	80-N/120-S	1623	3327-532	509.55
-----	------------	------	----------	--------

### 20 x 10 x 12 – No Recess

GRAIN	GRIT	MAX RPM	ORDER NO.	PRICE EACH
94A	60-L	1623	3327-558	\$623.10

# Centerless & Cylindrical Wheels



1

**Buy Ctn Qty**  
(Where shown)  
**Deduct 10%**



## 24 x 1-1/2 x 12 – No Recess

GRAIN	GRIT	MAX RPM	ORDER NO.	PRICE EACH
94A	60-K6	1353	3327-616*	\$272.35

\*CARTON QTY.= 2

## 24 x 2 x 12 – No Recess

GRAIN	GRIT	MAX RPM	ORDER NO.	PRICE EACH
94A	60-K	1353	3327-656*	\$272.35
94A	60-L	1353	3327-658*	272.35
94A	60-M	1353	3327-660*	272.35
94A	80-O	1353	3327-676*	272.35

### HARD SIDE

94A	80-N6/120-S	1353	3327-672*	311.40
-----	-------------	------	-----------	--------

\*CARTON QTY.= 2

## 24 x 2-1/2 x 12 – No Recess

GRAIN	GRIT	MAX RPM	ORDER NO.	PRICE EACH
94A	80-N/120-S	1353	3327-712*	\$337.90

\*CARTON QTY.= 2

## 24 x 3 x 12 – No Recess

GRAIN	GRIT	MAX RPM	ORDER NO.	PRICE EACH
94A	60-K	1353	3327-736	\$299.80

### HARD SIDE

94A	80-N/120-S	1353	3327-752	334.40
-----	------------	------	----------	--------

## 24 x 3 x 12 – Rec 1/5 14-1/2 x 1"

GRAIN	GRIT	MAX RPM	ORDER NO.	PRICE EACH
94A	60-K	1353	3327-776	\$314.25

## 24 x 4 x 12 – No Recess

GRAIN	GRIT	MAX RPM	ORDER NO.	PRICE EACH
94A	60-K	1353	3327-816	\$404.95
94A	60-L	1353	3327-818	404.95
94A	80-M	1353	3327-830	404.95

### HARD SIDE

94A	80-N/120-S	1353	3327-834	449.85
-----	------------	------	----------	--------

## 24 x 6 x 12 – No Recess

GRAIN	GRIT	MAX RPM	ORDER NO.	PRICE EACH
94A	60-K	1353	3327-866	\$548.25
94A	60-L	1353	3327-868	548.25
94A	80-J	1353	3327-874	548.25
94A	80-M	1353	3327-880	548.25

### HARD SIDE

94A	80-N/120-S	1353	3327-884	592.45
-----	------------	------	----------	--------

## 24 x 8 x 12 – No Recess

GRAIN	GRIT	MAX RPM	ORDER NO.	PRICE EACH
72C	60-L6	1353	3327-900	\$895.65
94A	60-K5	1353	3327-916	714.85
94A	60-L5	1353	3327-918	714.85
94A	60-M6	1353	3327-920	714.85
94A	80-J5	1353	3327-924	714.85
94A	80-L5	1353	3327-928	714.85

## 24 x 10 x 12 – No Recess

GRAIN	GRIT	MAX RPM	ORDER NO.	PRICE EACH
94A	60-K5	1353	3327-956	\$943.50
94A	60-L5	1353	3327-958	943.50
94A	60-M6	1353	3327-960	943.50

## 24 x 20 x 12 – No Recess

GRAIN	GRIT	MAX RPM	ORDER NO.	PRICE EACH
94A	60-K5	1353	3327-986	\$1960.65
94A	60-L5	1353	3327-988	1960.65
94A	60-M6	1353	3327-990	1960.65

# Feed/Regulating Wheels

1

Aluminum Oxide – Rubber Bonded For All Centerless Grinding Machines  
Isostatic process assures perfect gripping with standard A-80-R2-RX grade

	MAX RPM	ORDER NO.	PRICE EACH
8 x 4 x 3 R 1/S 4-1/4 x 1/2" O/S 4-1/4 x 1-1/2"	1020	3329-040	\$128.75
9 x 2 x 4	1020	3329-120	74.00
9 x 4 x 4 R 2/S 5-1/2 x 5/8"	1020	3329-140	126.00
10 x 6 x 5-1/2 R 2/S 6-1/2 x 1/2"	920	3329-260	250.20
12 x 1 x 5	800	3329-410	66.50
12 x 2 x 5	800	3329-420	115.20
12 x 2-1/2 x 5	800	3329-425	158.15
12 x 3 x 5	800	3329-430	183.40
12 x 4 x 5 R 2/S 7-1/2 x 1/2"	800	3329-442	229.45

	MAX RPM	ORDER NO.	PRICE EACH
12 x 6 x 5 R 1/S 7-1/2 x 1/2" O/S 7-1/2 x 1-1/2"	800	3329-462	\$350.95
12 x 6 x 5 R 2/S 7-1/2 x 1-1/2"	800	3329-464	350.95
12 x 8 x 5 R 1/S 7-1/2 x 1-1/2"	800	3329-480	445.40
12 x 8 x 5 R 1/S 7-1/2 x 1-1/2" O/S 7-1/2 x 2-1/2"	800	3329-482	445.40
12 x 10 x 5 R 1/S 8 x 1-1/2" O/S 8 x 2"	800	3329-502	561.75

	MAX RPM	ORDER NO.	PRICE EACH
14 x 8 x 5 R 1/S 8 x 1-1/2" O/S 8 x 2"	650	3329-682	\$595.25
14 x 8 x 5 R 1/S 8 x 1-1/2" O/S 8 x 2-1/2"	650	3329-684	595.25
14 x 20 x 5 R 2/S 8 x 1-1/2"	650	3329-802	1471.85
14 x 20 x 6 R 2/S 8-1/2 x 1-1/2"	650	3329-804	1471.85

# Mounted Points

## Group "A" Special Shapes

3

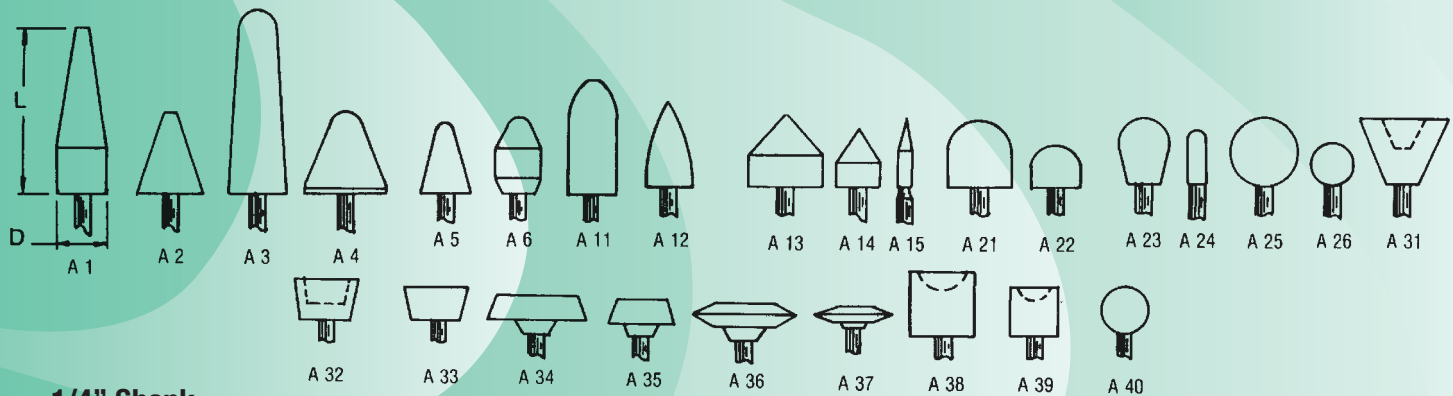

### 1/4" Shank

SHAPE NO.	SIZE DIAM.	LGTH.	ORDER NO.	PRICE EACH
A1	3/4"	2-1/2"	3133-001	\$2.45
A2	1"	1-1/4"	3133-002	1.50
A3	1"	2-3/4"	3133-003	2.65
A4	1-1/4"	1-1/4"	3133-004	1.70
A5	3/4"	1-1/8"	3133-005	1.40
A6	3/4"	1-1/8"	3133-006	1.40
A11	7/8"	2"	3133-011	1.80
A12	11/16"	1-1/4"	3133-012	1.40
A13	1-1/8"	1-1/8"	3133-013	1.70

SHAPE NO.	SIZE DIAM.	LGTH.	ORDER NO.	PRICE EACH
A14	11/16"	7/8"	3133-014	\$1.05
A15	1/4"	1-1/16"	3133-015	1.35
A21	1"	1"	3133-021	1.15
A22	3/4"	5/8"	3133-022	1.05
A23	3/4"	1"	3133-023	1.05
A24	1/4"	3/4"	3133-024	0.95
A25	1"	1"	3133-025	1.15
A26	5/8"	5/8"	3133-026	1.05
A31	1-3/8"	1"	3133-031	1.40

SHAPE NO.	SIZE DIAM.	LGTH.	ORDER NO.	PRICE EACH
A32	1"	5/8"	3133-032	\$1.05
A33	1"	1/2"	3133-033	1.05
A34	1-1/2"	3/8"	3133-034	1.25
A35	1"	3/8"	3133-035	1.05
A36	1-5/8"	3/8"	3133-036	1.40
A37	1-1/4"	1/4"	3133-037	1.05
A38	1"	1"	3133-038	0.95
A39	3/4"	3/4"	3133-039	0.80
A40	3/4"	3/4"	3133-040	1.05

## Group "W" Plain Shapes



### 1/8" X 1-1/2" Shank

SHAPE NO.	SIZE DIAM.	LGTH.	ORDER NO.	PRICE EACH
W141	3/32	5/32	3133-141	\$0.70
W142	3/32	1/4	3133-142	0.70
W143	1/8	1/8	3133-143	0.70
W144	1/8	1/4	3133-144	0.70
W145	1/8	3/8	3133-145	0.75
W146	1/8	1/2	3133-146	0.75
W149	5/32	1/4	3133-149	0.70
W150	3/16	1/16	3133-150†	0.70
W151	3/16	1/8	3133-151	0.70
W152	3/16	1/4	3133-152	0.70
W153	3/16	3/8	3133-153	0.75
W154	3/16	1/2	3133-154	0.75
W155	13/64	1/4	3133-155†	0.70
W157	1/4	1/16	3133-157	0.70
W158	1/4	1/8	3133-158	0.70
W159	1/4	3/16	3133-159	0.70
W160	1/4	1/4	3133-160	0.70
W161	1/4	5/16	3133-161	0.75
W162	1/4	3/8	3133-162	0.75
W163	1/4	1/2	3133-163	0.75
W164	1/4	3/4	3133-164	0.80
W165	5/16	1/16	3133-165	0.70
W166	5/16	1/8	3133-166	0.70
W167	5/16	1/4	3133-167	0.70
W168	5/16	5/16	3133-168	0.75
W169	5/16	3/8	3133-169	0.75
W170	5/16	1/2	3133-170	0.75
W171	5/16	3/4	3133-171	0.80
W172	3/8	1/16	3133-172	0.70
W173	3/8	1/8	3133-173	0.70
W174	3/8	1/4	3133-174	0.70

SHAPE NO.	SIZE DIAM.	LGTH.	ORDER NO.	PRICE EACH
W175	3/8	3/8	3133-175	\$0.75
W176	3/8	1/2	3133-176	0.75
W177	3/8	3/4	3133-177	0.80
W178	3/8	1	3133-178	0.85
W179	3/8	1-1/4	3133-179†	1.10
W181	1/2	1/16	3133-181	0.70
W182	1/2	1/8	3133-182	0.70
W183	1/2	1/4	3133-183	0.70
W184	1/2	3/8	3133-184	0.70
W185	1/2	1/2	3133-185	0.75
W186	1/2	3/4	3133-186	0.80
W187	1/2	1	3133-187	0.85
W190	5/8	1/16	3133-190	0.75
W191	5/8	1/8	3133-191	0.75
W192	5/8	1/4	3133-192	0.75
W193	5/8	3/8	3133-193	0.80
W194	5/8	1/2	3133-194	0.80
W195	5/8	3/4	3133-195	0.85
W199	3/4	1/16	3133-199	0.75
W200	3/4	1/8	3133-200	0.75
W201	3/4	1/4	3133-201	0.75
W202	3/4	3/8	3133-202	0.80
W203	3/4	1/2	3133-203	0.80
W204	3/4	3/4	3133-204	0.85
W210	7/8	1/16	3133-210	0.80
W211	7/8	1/8	3133-211	0.80
W212	7/8	1/4	3133-212	0.80
W213	7/8	3/8	3133-213	0.85
W214	15/16	1/4	3133-214	0.80
W215	1	1/8	3133-215	0.80
W216	1	1/4	3133-216	0.80

### 1/4" X 1-1/2" Shank

SHAPE NO.	SIZE DIAM.	LGTH.	ORDER NO.	PRICE EACH
W178	3/8	1	3133-378	\$0.85
W187	1/2	1	3133-387	0.85
W188	1/2	1-1/2	3133-188	1.30
W189	1/2	2	3133-189	1.65
W194	5/8	1/2	3133-394	0.80
W195	5/8	3/4	3133-395	0.85
W196	5/8	1	3133-196	0.95
W197	5/8	2	3133-197	1.75
W198	5/8	2-1/2	3133-198	2.15
W204	3/4	3/4	3133-404	0.85
W205	3/4	1	3133-205	0.95
W206	3/4	1-1/4	3133-206	1.15
W207	3/4	1-1/2	3133-207	1.40
W208	3/4	2	3133-208	1.75
W209	3/4	2-1/2	3133-209	2.15
W213	7/8	3/8	3133-413	0.85
W217	1	3/8	3133-217	0.85
W218	1	1/2	3133-218	0.85
W219	1	3/4	3133-219	0.95
W220	1	1	3133-220	1.05
W221	1	1-1/2	3133-221	1.45
W222	1	2	3133-222	1.80
W223	1	2-1/2	3133-223	2.20
W224	1	3	3133-224	2.55
W225	1-1/4	1/4	3133-225	0.95
W226	1-1/4	3/8	3133-226	1.05
W227	1-1/4	1/2	3133-227	1.05
W228	1-1/4	3/4	3133-228	1.10
W229	1-1/4	1	3133-229	1.25
W230	1-1/4	1-1/4	3133-230	1.45
W231	1-1/4	1-1/2	3133-231	1.75
W232	1-1/4	2	3133-232	2.15
W235	1-1/2	1/4	3133-235	1.05
W236	1-1/2	1/2	3133-236	1.10
W237	1-1/2	1	3133-237	1.30
W238	1-1/2	1-1/2	3133-238	1.80
W239	1-1/2	2	3133-239	2.20
W242	2	1	3133-242	1.65
W243	2	1-1/2	3133-243	2.20
W244	2	2	3133-244	2.80
W245	2	2-1/2	3133-245†	3.35

† Limited Quantities

# Mounted Points

## Group "B" Special Shapes

3

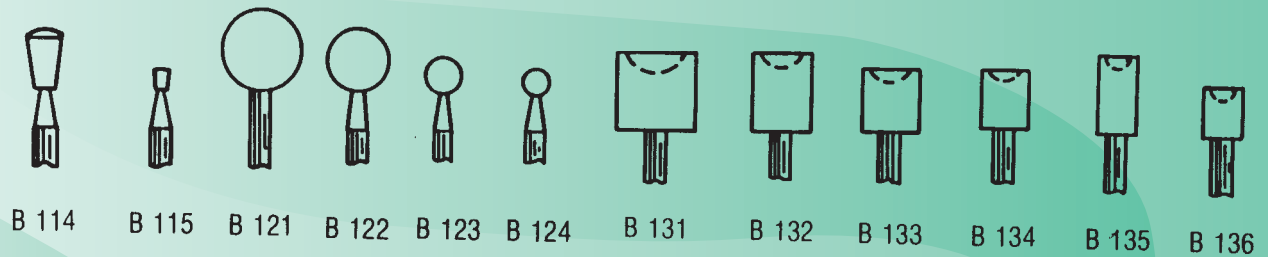
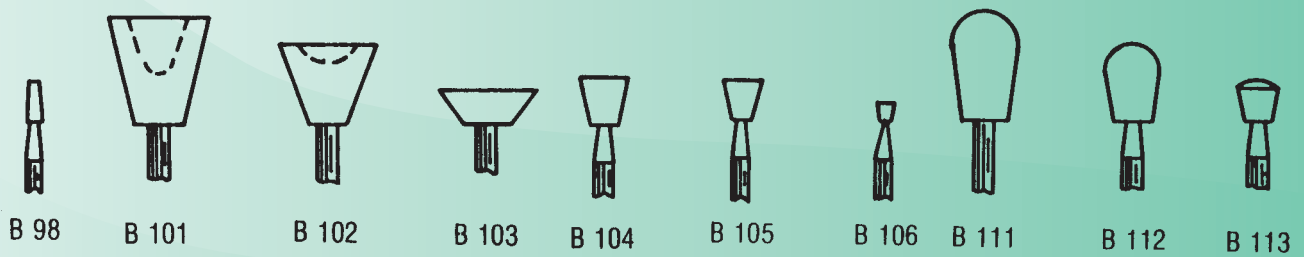
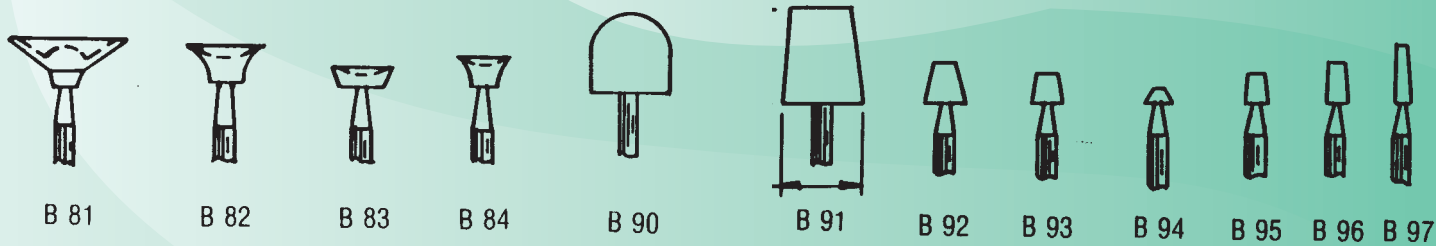
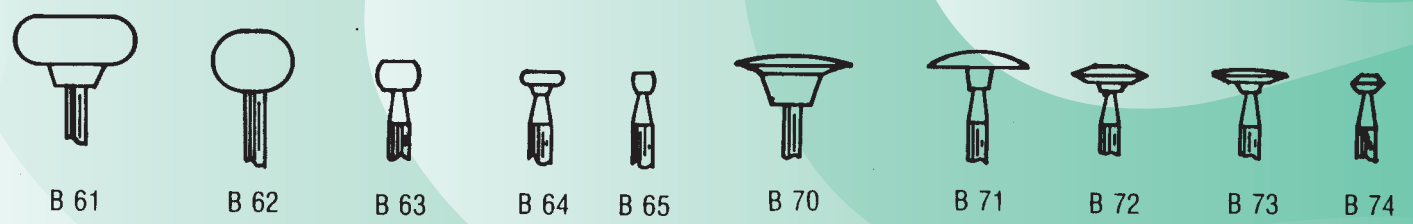
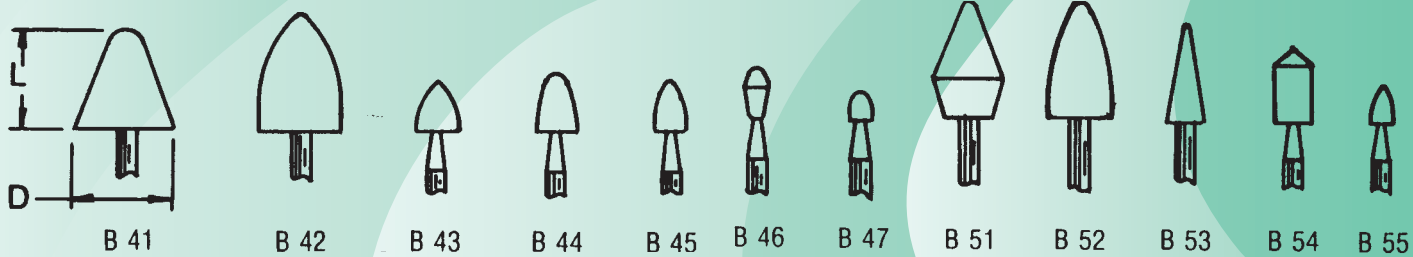

### 1/8' Shank

SHAPE NO.	SIZE DIAM.	LGTH.	ORDER NO.	PRICE EACH	SHAPE NO.	SIZE DIAM.	LGTH.	ORDER NO.	PRICE EACH	SHAPE NO.	SIZE DIAM.	LGTH.	ORDER NO.	PRICE EACH	SHAPE NO.	SIZE DIAM.	LGTH.	ORDER NO.	PRICE EACH
B41	5/8"	5/8"	3133-041	\$1.05	B63	1/4"	3/16"	3133-063	\$0.80	B92	1/4"	1/4"	3133-092	\$0.80	B112	3/8"	1/2"	3133-112	\$0.90
B42	1/2"	3/4"	3133-042	0.95	B64	1/4"	1/16"	3133-064	0.80	B93	3/16"	3/16"	3133-093	0.80	B113	1/4"	1/4"	3133-113	0.80
B43	1/4"	5/16"	3133-043	0.90	B65	1/8"	1/8"	3133-065	0.80	B94	11/64"	3/32"	3133-094	0.80	B114	7/32"	3/8"	3133-114	0.90
B44	7/32"	5/8"	3133-044	0.90	B70	3/4"	1/8"	3133-070	0.90	B95	1/8"	3/16"	3133-095	0.80	B115	3/32"	1/8"	3133-115	0.80
B45	3/16"	5/16"	3133-045	0.90	B71	5/8"	3/32"	3133-071	0.90	B96	1/8"	1/4"	3133-096	0.80	B121	1/2"	1/2"	3133-121	0.90
B46	1/8"	5/16"	3133-046	0.90	B72	1/2"	1/8"	3133-072	0.80	B97	1/8"	3/8"	3133-097	0.90	B122	3/8"	3/8"	3133-122	0.90
B47	1/8"	5/32"	3133-047	0.80	B73	1/2"	1/8"	3133-073	0.80	B98	3/32"	1/4"	3133-098	0.80	B123	3/16"	3/16"	3133-123	0.80
B51	7/16"	3/4"	3133-051	0.95	B74	7/32"	3/32"	3133-074	0.80	B101	5/8"	11/16"	3133-101	1.05	B124	1/8"	1/8"	3133-124	0.80
B52	3/8"	3/4"	3133-052	0.95	B81	3/4"	3/16"	3133-081	0.90	B102	5/8"	1/2"	3133-102	0.95	B131	1/2"	1/2"	3133-131	0.70
B53	1/4"	5/8"	3133-053	0.95	B82	1/2"	1/4"	3133-082	0.80	B103	5/8"	3/16"	3133-103	0.90	B132	3/8"	1/2"	3133-132	0.70
B54	1/4"	1/2"	3133-054	0.90	B83	3/8"	3/16"	3133-083	0.80	B104	5/16"	3/8"	3133-104	0.90	B133	3/8"	3/8"	3133-133	0.70
B55	1/8"	1/4"	3133-055	0.80	B84	5/16"	3/16"	3133-084	0.80	B105	1/4"	1/4"	3133-105	0.80	B134	5/16"	3/8"	3133-134	0.70
B61	3/4"	5/16"	3133-061	0.95	B90	1/2"	1/2"	3133-090	0.90	B106	1/8"	7/64"	3133-106	0.80	B135	1/4"	1/2"	3133-135	0.70
B62	3/8"	1"	3133-062	0.90	B91	1/2"	5/8"	3133-091	0.95	B111	7/16"	11/16"	3133-111	0.95	B136	1/4"	5/16"	3133-136	0.70

# Diamond Tools

## For Surface Grinders – 6 Inch Overall Length



**Preferred Grade— Made in USA**  
For machine or hand dressing of all wheels. Designed for longer tool life.

**Economy Grade**  
For general purpose dressing and truing of soft wheels.

RECOMMENDED DIAMOND SIZE			
WHEEL FACE	CARAT WT.	WHEEL FACE	CARAT WT.
1/4	1/4	2	1-1/2
1/2	1/3	3	1-3/4
3/4	1/2	3-1/2	2
1	3/4	4	2-1/2
1-1/4	1	6	3
1-1/2	1-1/4	8 and up	3-1/2

ECONOMY				PREFERRED – USA	
SHANK SIZE	CARAT SIZE	ORDER NO.	PRICE	ORDER NO.	PRICE
3/8	1/4	3131-311	\$ 4.30	3131-341	\$18.50
3/8	1/3	3131-312	6.35	3131-342	22.00
3/8	1/2	3131-313	8.70	3131-343	27.10
3/8	3/4	3131-314	12.95	3131-344	39.00
3/8	1	3131-315	17.20	—	—
3/8	1-1/2	3131-316	25.80	—	—
3/8	2	3131-317	34.20	—	—
3/8	3	3131-318	48.55	—	—
7/16	1/4	3131-321	4.30	3131-361	18.50
7/16	1/3	3131-322	6.35	3131-362	22.00
7/16	1/2	3131-323	8.70	3131-363	27.10
7/16	3/4	3131-324	12.95	3131-364	39.00
7/16	1	3131-325	17.20	—	—
7/16	1-1/2	3131-326	25.80	—	—
7/16	2	3131-327	34.20	—	—
7/16	3	3131-328	48.55	—	—
1/2	1/4	3131-331	4.30	—	—
1/2	1/3	3131-332	6.35	—	—
1/2	1/2	3131-333	8.70	—	—
1/2	3/4	3131-334	12.95	—	—
1/2	1	3131-335	17.20	—	—
1/2	1-1/2	3131-336	25.80	—	—
1/2	2	3131-337	34.20	—	—
1/2	3	3131-338	48.55	—	—

## Coned Radius Dressers



A precision shaped tool used for intricate form & radius dressing.

CARAT SIZE	INCLUDED ANGLE	3/8 x 2-1/2 SHANK		7/16 x 2-1/2 SHANK	
		ORDER NO.	PRICE	ORDER NO.	PRICE
1/4	60 DEG	3131-461	\$44.00	3131-481	\$44.00
1/4	75 DEG	3131-462	40.00	3131-482	40.00
1/4	90 DEG	3131-463	33.75	3131-483	33.75
1/3	60 DEG	3131-464	70.00	3131-484	70.00
1/3	75 DEG	3131-465	62.00	3131-485	62.00
1/3	90 DEG	3131-466	42.65	3131-486	42.65
1/2	60 DEG	3131-467	94.00	3131-487	94.00
1/2	75 DEG	3131-468	82.00	3131-488	82.00
1/2	90 DEG	3131-469	64.00	3131-489	64.00

## Hand Diamond Dressers



7/16" Shank Size - 8" Overall Length

Dressers fitted with plastic handles. Ideal for dressing wheels for Surface Grinders, Universal Grinders, etc.

CARAT SIZE	ORDER NO.	PRICE
1/4	3131-451	\$6.75
1/3	3131-452	8.55
1/2	3131-453	10.75
3/4	3131-454	18.10
1	3131-455	25.65

## Economy - Super Value 1/4 Carat - Single Point



SHANK SIZE	ORDER NO.	PRICE
3/8 x 2	3131-040	\$4.55
3/8 x 3	3131-045	4.55
7/16 x 2	3131-080	4.55
7/16 x 3	3131-085	4.55

## Convex & Concave Radii Forming Tools MR and FR Series

Designed to form convex and concave radii on small diameter grinding wheels. 3/8" x 2" Shanks.



### MR Series Convex Radii

TOOL NO.	RADIUS	ORDER NO.	PRICE
MR-2	.020-.125	3131-582	\$12.45
MR-4	.125-.250	3131-584	14.00
MR-6	.250 up	3131-586	17.20

### FR Series Concave Radii

TOOL NO.	RADIUS	ORDER NO.	PRICE
FR-10	.010	3131-550	\$10.00
FR-15	.015	3131-555	10.00
FR-20	.020	3131-560	10.00
FR-32	.032	3131-565	11.30
FR-62	.062	3131-570	12.90
FR-125	.125	3131-575	12.90

## Phonopoint Diamond Dressing Tools

Small cone pointed tools used for precision form dressing.



SHANK SIZE	60 DEG		75 DEG		90 DEG	
	ORDER NO.	PRICE	ORDER NO.	PRICE	ORDER NO.	PRICE
1/8 x 1"	3131-536	\$6.20	3131-541	\$5.60	3131-546	\$5.10
3/16 x 1"	3131-537	6.60	3131-542	6.00	3131-547	5.40
1/4 x 1-1/2"	3131-539	7.00	3131-544	6.30	3131-549	5.50

## Thread Grinding Diamond Tools



For use on Jones & Lamson, Ex-Cell-O & similar thread grinding equipment.

SIZE	MACHINE	60 DEG		90 DEG	
		ORDER NO.	PRICE	ORDER NO.	PRICE
1/4 x 1	J & L	3131-605	\$9.80	3131-607	\$9.80
3/8 x 1-5/8	EX-CELL-O	3131-615	9.80	—	—

# Diamond Tools

## Machine-Use Single Point Diamond Dressers Preferred Grade Diamond

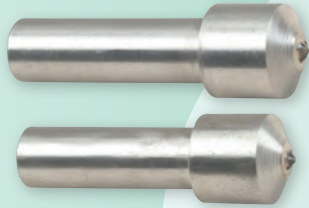

CARAT SIZE	LARGE NORTON Shank: 7/16 x 1-1/2 Head: 5/8" x 5/8"		CINCINNATI Shank: 7/16 x 2 Head: 5/8" x 5/8"	
	ORDER NO.	PRICE	ORDER NO.	PRICE
1/4	3131-391	\$18.60	3131-381	\$18.60
1/3	3131-392	22.40	3131-382	22.40
1/2	3131-393	30.00	3131-383	30.00
3/4	3131-394	44.00	3131-384	44.00
1	3131-395	60.00	3131-385	60.00
1-1/2	3131-396	95.10	3131-386	95.10

## Natural & Lapped Chisels



For use on radius dressers to form radii, steps, or contours. Tools shown are 1/4 Carat.

SHANK SIZE	NATURAL CHISEL EDGE		60° LAPPED CHISEL	
	ORDER NO.	PRICE	ORDER NO.	PRICE
3/8 x 2-1/2"	3131-520	\$30.10	3131-500	\$47.30
7/16 x 2-1/2"	3131-530	30.10	3131-510	47.30

## Multi Point Cluster Dressing Tools

5/8" Diameter Head,  
7 Diamonds

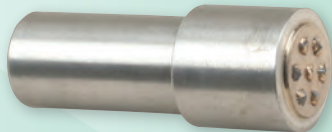

For straight face and side dressing finishes.

CARAT SIZE	3/8 SHK ORDER NO.	7/16 SHK ORDER NO.	1/2 SHK ORDER NO.	PRICE
1	3131-400	3131-415	3131-430	\$26.00
2	3131-405	3131-420	3131-435	34.00
3	3131-410	3131-425	3131-440	42.00

## Diamond Hones

- Features:
- Resin Bond, 100% Concentration.
  - Diamond Length: 1"
  - 3/8" width square
  - Overall Length: 4"



### DOUBLE END

GRIT	ORDER NO.	PRICE
100/180	3131-640	\$39.00
150/220	3131-641	39.00
180/320	3131-642	39.00
220/400	3131-643	39.00

### SINGLE END

GRIT	ORDER NO.	PRICE
100	3131-644	\$27.00
150	3131-645	27.00
220	3131-646	27.00
320	3131-647	27.00
400	3131-648	27.00
600	3131-649	27.00

## Diamond Wheel Dressers



SIZE	ORDER NO.	PRICE EACH
0	3131-670	\$7.40
1	3131-671	8.35
2	3131-672	13.05

## Cutters For Diamond Wheel Dressers



SIZE	ORDER NO.	PRICE EACH
0	3131-675	\$1.55
1	3131-676	2.35
2	3131-677	4.65

## T-Handle Diamond Dressers



Used for hand truing and dressing. A broad, flat surface of diamonds in a matrix. 3/8" x 6" Shank. 1/2" W x 1-1/2" L head. 6-1/2" OAL.

GRADE	NO. OF DIAMONDS	ORDER NO.	PRICE
Standard	28	3131-591	\$80.00
Medium	38	3131-592	88.00
Heavy Duty	48	3131-593	96.00



# Diamond Wheels

## Straight Diamond Wheels – Type D1A1

Resin Bond, With Diamonds in Periphery  
1/8" Diamond Depth, 150 Grit

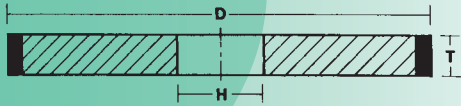

75 Concentration – Economical Grinding  
100 Concentration – For Surface Grinding, Longer life.

D DIAM.	T THICKNESS	H HOLE DIAM.	75 CONCENTRATION		100 CONCENTRATION	
			150 GRIT ORDER NO.	PRICE	150 GRIT ORDER NO.	PRICE
4	1/8	1-1/4	-	-	3130-128	\$ 78.25
4	1/4	1-1/4	-	-	3130-148	110.00
5	1/8	1-1/4	-	-	3130-228	85.35
5	1/4	1-1/4	-	-	3130-248	125.00
6	1/8	1-1/4	3130-323	\$ 86.25	3130-328	106.50
6	1/4	1-1/4	3130-343	111.10	3130-348	135.50
6	3/8	1-1/4	3130-363	150.50	3130-368	170.00
6	1/2	1-1/4	3130-383	158.25	3130-388	210.00
7	1/8	1-1/4	-	-	3130-428	138.00
7	1/4	1-1/4	3130-443	133.35	3130-448	170.00
7	3/8	1-1/4	-	-	3130-468	191.50
7	1/2	1-1/4	-	-	3130-488	232.00
8	1/4	1-1/4	-	-	3130-548	208.00
8	1/2	1-1/4	-	-	3130-588	252.00

Other Grits, Diamond Depths and Arbor Hole Diameters available.

## Diamond Cut-Off Wheels – Type D1A1R

Resin Bond, 100% Concentration, 1/4" Depth

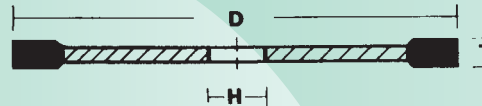

For cutting-off on Carbide.

D DIAM.	T THICKNESS	H HOLE DIAM.	GRIT	ORDER NO.	PRICE
6	.035	1-1/4	150	3130-910	\$ 84.45
6	.045	1-1/4	150	3130-915	103.10

## Diamond Face Wheels – Type D6A2C

Resin Bond, Plate Mounted, 150 Grit

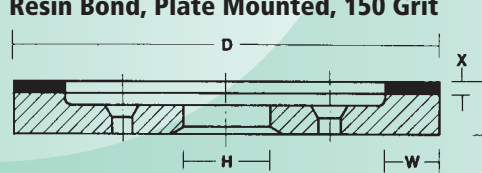

For Carbide Tool Grinders. Bolt holes countersunk for maximum safety.

D DIAM.	T THICKNESS	H HOLE DIAM.	W RIM WIDTH	X DIAMOND DEPTH	CONCN.	ORDER NO.	PRICE
6	3/4	1-1/4	1/2	1/8	75%	3130-953	\$161.00
6	3/4	1-1/4	1/2	1/8	100%	3130-958	184.00
6	3/4	1-1/4	3/4	1/16	75%	3130-963	97.80
6	3/4	1-1/4	3/4	1/16	100%	3130-968	183.00
6	1	1-1/4	3/4	1/16	75%	3130-983	131.00

## Diamond Flaring Cup Wheels – Type D11V9

Resin Bond Diamond in the periphery and on the face.  
Grind with face only.

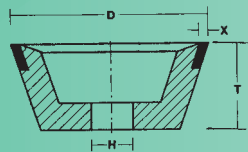

For use with Tool & Cutter Grinders.

D DIAM.	T THICKNESS	H HOLE DIAM.	X DIAMOND DEPTH	CONCN.	100 GRIT ORDER NO.	150 GRIT ORDER NO.	PRICE
3-3/4	1-1/2	1-1/4	1/8	75%	3129-121	3129-123	\$ 99.60
3-3/4	1-1/2	1-1/4	1/8	100%	3129-126	3129-128	112.00
5	1-3/4	1-1/4	1/8	75%	3129-221	3129-223	114.70
5	1-3/4	1-1/4	1/8	100%	3129-226	3129-228	126.25

## Diamond Flaring Cup Wheels – Type D11A2

Resin Bond. Diamond on the face (rim).  
100% Concentration, 150 Grit

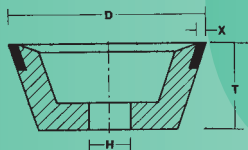

For use with Tool & Cutter Grinders.

D DIAM.	T THICKNESS	H HOLE DIAM.	W RIM WIDTH	X DIAMOND DEPTH	ORDER NO.	PRICE
3	7/8	1-1/4	3/8	1/8	3129-308	\$105.40
4	1-1/4	1-1/4	1/2	1/8	3129-318	129.00
5	1-3/4	1-1/4	3/8	1/8	3129-328	150.50

## Diamond Dish Wheels – Type D12A2

Resin Bond. Diamond on the face (rim).  
100% Concentration, 150 Grit

T THICKNESS	H HOLE DIAM.	B DISH ANGLE	E BACK THICKNESS	K INSIDE FLAT	X DIAMOND DEPTH
1"	1-1/4	30	1/2	2-5/8	1/8

Used for sharpening Cutting Tools.

D DIAMETER	W RIM WIDTH	ORDER NO.	PRICE
6	3/16	3129-358	\$129.00
6	1/4	3129-368	142.00
6	3/8	3129-378	189.00

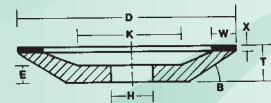

## 5 Inch Diamond Facewheels– 5" x 1/4" x 3"

Resin Bond, Steel Core, 100% Concentration

For Leonard, Cold Grind and similar type grinders.

STANDARD SECTION	120 GRIT ORDER NO.	220 GRIT ORDER NO.	320 GRIT ORDER NO.	PRICE
1/32	3129-407	3129-409	3129-412	\$172.00
1/16	3129-427	3129-429	3129-432	189.00



# Diamond Dressers

## Optical Radius Angle Dresser Visual Universal Wheel Dresser

Adaptable to surface grinders and universal tool grinders. 3X lens magnification through the spindle allows the operator to view the diamond point for radii and angle forming. Easy and accurate.

Order No. 3131-684  
Price: ..... \$377.90

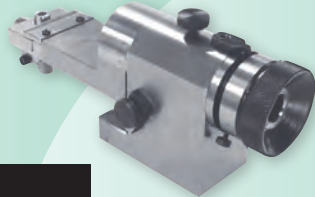

SPECIFICATIONS	
Center Height	2.5"
Max. Wheel Diameter	8"
Max. Convex Radius	1/2"
Max. Concave Radius	1"
Dressing Angle	90 - 0 - 90 (1 deg incr)
Tangential Travel	.89" either side
Mounting Surface	3.27 x 1.87"
Overall Length	8.39"
Overall Height	3.94"

- Accuracy to 0.0001"
- Gauge block setting
- Radius and angle can be done perfectly tangent
- Compact design
- Wt. 7.7 lbs.
- Complete with Diamond Dressers, Hex Keys and Wood Case.

## Precision Punch Former & Radius Wheel Dresser

For grinding wheel and punch forming applications. Concave and Convex radii. Hardened tool steel construction. Fitted case.

Order No. 3131-686  
Price: .....\$672.00

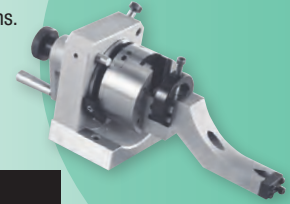

SPECIFICATIONS	
Max. Dia. - Workpiece	1-1/4"
V-Block	1-3/16"
Adjusting System	Rack and Pinion
Center Height	3-1/2"
Indexing Divisions	24 every 15 Degree +/-10 seconds
Angle Setting	By sine system
Roundness	0.0001"
Parallelism	w/i 0.0001" in 4"
Squareness	w/i 0.0002" in 4"
Graduation	360 Deg.
Weight	17.0 lbs.

## Radius and Angle Dresser

For use on all OD, ID and surface grinding applications.

No height gage or set-up aids required. Radius is set on the grinder by measuring over the two pins or by inserting a gage block, for direct reading. Inside or outside radius is determined by using either the left hand or right hand pins. Uses 3/8" shank diamond tool.

Order No. 3131-687 Price: ..\$311.40

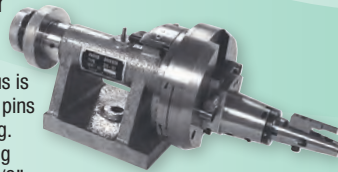

SPECIFICATIONS			
Max. Wheel Diameter	12"	Center Line Of Tool	3.4"
Max. Convex Radii	0 to 1-5/8"	Overall Length	16-5/8"
Max. Concave Radii	0 to 4"	Weight	30 lbs.
Tangent Travel	2"	Accuracy	.0005"

## Profile Wheel Dresser

Accurate and versatile Radius and Angle Wheel Dresser.

\*Fast and easy set-ups without elaborate accessories. Only a micrometer and hex key wrench are needed.

\*Dress 2 angles tangent to a radius in one continuous motion to within .0001".

\*Precise and sharp contours, concave and convex, are consistently obtained at a full 180 Degree range.

Order No. 3131-685  
Price: .....\$492.00



SPECIFICATIONS	
Max. Dia. - Workpiece	8"
Convex Radii	0 to 1-1/2"
Concave Radii	.030 to 1-1/2"
Center Height	3-1/2"
Height to center of diamond	6-1/2"
Dia. of Setting Pins	10mm
Overall Height	7"
Base	4-3/4 x 3-1/2 x 1-1/4"

## Diamond Nib Holder

Use on surface grinders.

Holds Diamond Dresser at 15 Deg. angle.

Base dimension: 2-1/2" x 6"

Keyway: 1/2" x 7/8"

Includes 7/16 x 2" 1/4 Carat dresser.

Order No. 3131-683 ...Price: \$21.45

Replacement Diamond Dresser

Order No. 3131-080 ...Price:\$4.55



## Hi-Low Adjustable Dresser

Use on all grinding machines.

Dress O.D. and face of wheels.

Adjustable to 7" Height.

Includes 3/8 x 3" 1/4 Ct. dresser.

Order No. 3131-681

Price: .....\$46.00

Replacement Diamond Dresser

Order No. 3131-045

Price: .....\$4.55



## Low-Boy Angle Dresser

Use on all grinding machines. Base Angle-Plate heavy, precision ground, square on six sides to .0005" accuracy. Side block pivots on hardened screws. Includes 3/8 x 2 1/4 Carat dresser.

Order No. 3131-682  
Price: .....\$76.75

Replacement  
Diamond Dresser-  
Order No. 3131-040  
Price: .....\$4.55

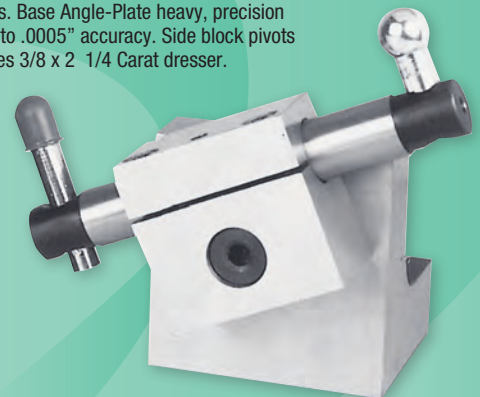

# Diamond & CBN Electro-Plated Mandrels/Jig Grinding Pins

**Coarse Grit 80/120**  
**Tolerance on Hardened Steel Shanks: +.0000/- .0006**

Diamond plated mandrels are used for internal grinding of glass, ceramics, cemented carbides, and other hard and abrasive materials.

CBN is ideal for High Speed Steels, such as M2, M3, M7 & T16; Die Steels, such as D2, D3, HB & A&O; Alloy Steels (harder than 50Rc); Nickel and Cobalt Base Super Alloys; Titanium, and Stainless Steels.

## STYLE I

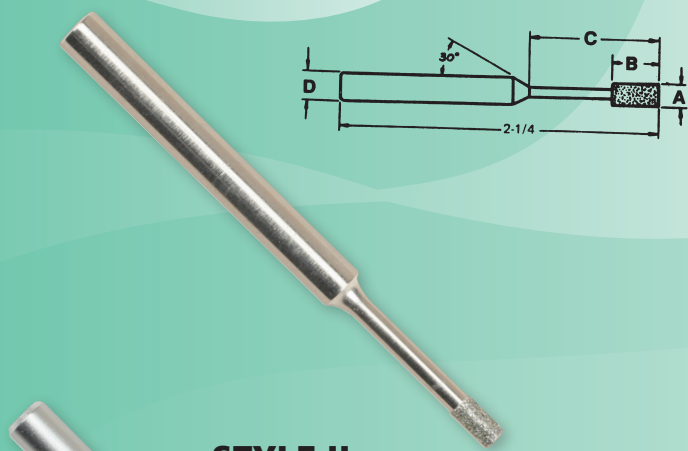

## STYLE II

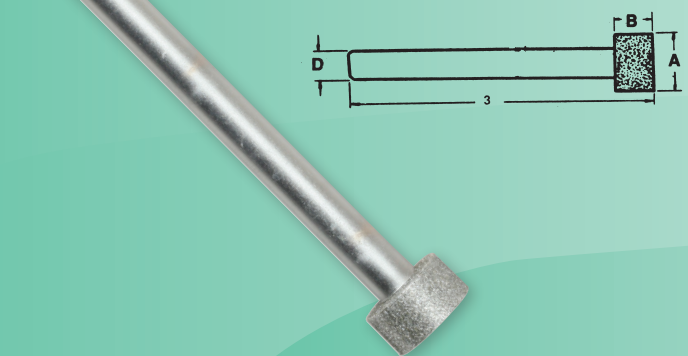

## STYLE I

A HEAD	B HEAD LENGTH	C NECK LENGTH	D SHANK SIZE	DIAMOND ORDER NO.	CBN ORDER NO.	PRICE
.020	1/16	1/8	1/8	3128-600	3126-600	\$11.00
.025	3/32	1/4	1/8	3128-601	3126-601	9.40
.030	3/32	1/4	1/8	3128-602	3126-602	9.40
.035	3/32	1/4	1/8	3128-603	3126-603	9.40
.040	1/8	3/8	1/8	3128-604	3126-604	9.40
.045	1/8	3/8	1/8	3128-605	3126-605	9.80
.050	1/8	3/8	1/8	3128-606	3126-606	9.80
.050	1/8	1	1/8	3128-607	3126-607	11.80
.055	1/8	3/8	1/8	3128-608	3126-608	9.90
.060	1/8	3/8	1/8	3128-609	3126-609	9.70
.060	1/8	1	1/8	3128-610	3126-610	11.70
.070	5/32	1/2	1/8	3128-611	3126-611	10.30
.070	5/32	1	1/8	3128-612	3126-612	11.80
.080	5/32	1/2	1/8	3128-613	3126-613	10.90
.080	5/32	1	1/8	3128-614	3126-614	12.00
.090	5/32	1/2	1/8	3128-615	3126-615	11.00
.090	5/32	1	1/8	3128-616	3126-616	12.10
.100	5/32	1/2	1/8	3128-617	3126-617	11.00
.100	5/32	1	1/8	3128-618	3126-618	12.30
.110	5/32	1/2	1/8	3128-619	3126-619	11.30
.110	5/32	1	1/8	3128-620	3126-620	12.30
.125	5/32	1/2	1/8	3128-621	3126-621	11.90
.125	5/32	1	1/8	3128-622	3126-622	13.00
.141	1/4	1	1/4	3128-623	3126-623	16.80
.156	1/4	1	1/4	3128-624	3126-624	19.40
.188	1/4	1	1/4	3128-625	3126-625	19.40
.218	1/4	1	1/4	3128-626	3126-626	19.40
.250	1/8	1	1/4	3128-627	3126-627	19.40
.250	1/4	1	1/4	3128-628	3126-628	19.40

## STYLE II

A HEAD	B HEAD LENGTH	D SHANK SIZE	DIAMOND ORDER NO.	CBN ORDER NO.	PRICE
.312	1/8	1/4	3128-640	3126-640	\$24.30
.312	1/4	1/4	3128-641	3126-641	27.90
.375	1/8	1/4	3128-642	3126-642	24.30
.375	1/4	1/4	3128-643	3126-643	27.90
.500	1/4	1/4	3128-644	3126-644	33.40
.500	3/8	1/4	3128-645	3126-645	33.40
.750	1/4	1/4	3128-646	3126-646	47.40
.750	1/2	1/4	3128-647	3126-647	47.40

# Diamond Polishing & Lapping Compounds

**"Universal Carrier"—**  
**Oil or Water Soluble Stocked in 5 Gram Disposable Plastic Syringes**

FINISH	COLOR	MICRON GRADE	MICRON RANGE	LIGHT CONCENTRATION		MEDIUM CONCENTRATION		HEAVY DUTY CONCENTRATION	
				ORDER NO.	PRICE	ORDER NO.	PRICE	ORDER NO.	PRICE
Super Fine	Yellow	3	1-5	3126-570	\$10.20	3126-571	\$12.90	3126-572	\$16.00
	Orange	5	4-8	3126-573	10.80	3126-574	15.00	3126-575	20.40
	Green	9	6-12	3126-576	11.80	3126-577	16.10	3126-578	21.40
Fine	Blue	15	10-22	3126-590	11.80	3126-591	16.10	3126-592	21.40
	Red	30	20-40	3126-593	11.80	3126-594	16.10	3126-595	21.40
	Brown	45	30-60	3126-596	11.80	3126-597	16.10	3126-598	21.40



# Type 1 Cut-Off Wheels – Tool Room, Die Grinder

## CGW Tool Room Wheels

### Aluminum Oxide – Resin Bonded

Reinforced: For stationary tool room and machine shop use. Fast cutting and clean finishes where precision is necessary. Non-Reinforced: Use on fixed base cut-off machines with the work piece clamped securely and the wheel properly guarded. Fast cutting with clean finish.



ZAGO-TB-FLEX WHEELS						
SIZE DIA. x THICK. x ARBOR	MAX. RPM	GRADE	STD. CTN.	ORDER NO.	PRICE EACH	
6 x .060 x 5/8	10186	A60-O/P	25	3896-604	\$2.71	
8 x .060 x 1-1/4	7640	A60-O/P	25	3898-608	4.22	
NON-REINFORCED						
6 x 1/32 x 5/8	7639	A60M	25	3890-230†	2.25	
6 x 1/16 x 5/8	7639	A60M	25	3890-245†	2.07	
7 x 1/32 x 1-1/4	6548	A60M	25	3890-265	3.63	
7 x 1/16 x 1/2	6548	A60M	25	3890-270	3.75	
7 x 1/8 x 1/2	6548	A60M	25	3890-300†	2.88	
7 x 1/8 x 1-1/4	6548	A60M	25	3890-315	4.44	
8 x 1/16 x 1-1/4	5729	A60M	25	3890-345	4.50	
8 x 1/8 x 1/2	5729	A60M	25	3890-360†	3.20	
8 x 1/8 x 1-1/4	5729	A60M	25	3890-370	5.10	

† Limited Quantities

## CGW Quickie Cut™

### Type 1 Quickie Cut™ Reinforced Rt. Angle Grinding Wheels

CGW Quickie Cut™ Reinforced Type 1 Cut-Off wheels are safe for use on Right Angle Grinders, providing excellent results on stainless steel, alloys, and ferrous. Select from B-Flex or Rigid configurations.



Buy Std. Ctn. Deduct 10%

ZAGO-TB-FLEX WHEELS						
SIZE DIA. x THICK. x ARBOR	SPEC	RPM	STD. CTN.	ORDER NO.	PRICE EACH	
4 x .040 x 5/8	ZA60-TB-FLEX	19,000	25	3898-650	\$1.25	
4 1/2 x .035 x 7/8	ZA60-TB-FLEX	13,300	25	3898-653	1.22	
5 x .040 x 7/8	ZA60-TB-FLEX	12,250	25	3898-656	1.46	
6 x .040 x 3/8	ZA60-TB-FLEX	10,200	25	3898-659	1.91	
6 x .040 x 1/2	ZA60-TB-FLEX	10,200	25	3898-662	1.91	
6 x .040 x 5/8	ZA60-TB-FLEX	10,200	25	3898-665	1.88	
6 x .040 x 7/8	ZA60-TB-FLEX	10,200	25	3898-668	1.55	
7 x 1/16 x 7/8	ZA60-TB-FLEX	8,500	25	3898-671	2.50	
ZA36T RIGID WHEELS						
4 1/2 x .045 x 7/8	ZA36-T-BF	13,300	25	3890-471	1.22	
5 x .045 x 7/8	ZA36-T-BF	12,250	25	3890-472	1.49	
6 x .045 x 7/8	ZA36-T-BF	10,200	25	3890-473	1.56	
7 x 1/16 x 7/8	ZA36-T-BF	8,500	25	3890-474	2.40	
9 x 1/16 x 5/8	ZA36-T-BF	6,600	25	3890-476	4.84	

## Weiler TIGER ABRASIVES

### Fiberglass Reinforced Aluminum Oxide - Resin Bonded

For tool room and machine shop use.

SIZE DIA. x THICK. x ARBOR	MAX. RPM	GRADE	STD. CTN.	ORDER NO.	PRICE EACH	
6 x .035 x 1/2	10200	A60T	25	6556-170†	\$1.90	
6 x .035 x 5/8	10200	A60T	25	6556-171†	1.90	
7 x .035 x 5/8	8740	A60T	25	6556-183	2.17	
7 x 1/16 x 1-1/4	8740	A60T	25	6556-193†	2.27	
8 x .035 x 1-1/4	7640	A60T	25	6556-199†	3.61	

† Limited Quantities

## Mounting Mandrels

For small diameter Type 1 Wheels

ARBOR SIZE	WHEEL THICKNESS	ORDER NO.	PRICE EACH
1/4"	.035 to 1/4	6556-489	\$6.71
3/8"	.035 to 1/4	6556-490	6.71
1/4", 3/8"	.035 to 1/4	6556-491	11.55

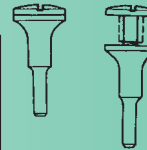

## Reusable Flange Adapting Nuts –

For use with 4-1/2" and 5" Diameter Cutoff Wheels on Angle Grinders. Can be used with Type 1 or Type 27 Cutoff wheels, .045 thru 1/8 thickness, 7/8" Arbor Hole.

Flange Nuts – (Pr)  
1-3/4" Dia. x 5/8-11 AH  
Order No. 6556-494  
Price: \$23.19

Spanner Wrench  
For Adapting Nuts  
Order No. 6556-495  
Price: \$18.66

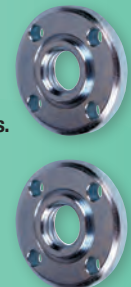

## Small Diameter – Portable Grinder Fiberglass Reinforced – Aluminum Oxide – Resin Bonded

For use on air or electric straight shaft high speed right angle and die grinders. Designed for fast, burr free cutting and notching. Works especially well on thin walled tube and pipe.

CGW					Weiler TIGER					FLEXOVIT USA				
SIZE DIA. x THICK. x ARBOR	MAX. RPM	GRADE	STD. CTN.	ORDER NO.	PRICE EACH	GRADE	STD. CTN.	ORDER NO.	PRICE EACH	GRADE	STD. CTN.	ORDER NO.	PRICE EACH	
3 x .035 x 1/4	24000	A60	50	3890-410*	\$0.90	A60T	100	6556-061	\$0.74	A60T	100	3893-610	\$2.03	
3 x .035 x 3/8	24000	A60	50	3890-415*	0.90	A60T	100	6556-062	0.74	A60T	100	3893-615	2.03	
3 x 1/16 x 1/4	24000	A36	50	3890-420	0.92	A36T	100	6556-065	0.80	A46T	50	3893-620	2.03	
3 x 1/16 x 3/8	24000	A36	50	3890-425	0.92	A36T	100	6556-068	0.80	A46T	50	3893-625	2.03	
3 x 1/8 x 1/4	24000	A24	25	3890-430	1.04	–	–	–	–	A36R	25	3893-630	2.84	
3 x 1/8 x 3/8	24000	A24	25	3890-435	1.04	A36T	50	6556-076	0.88	A36R	25	3893-635	2.84	
4 x .035 x 1/4	19000	A60	50	3890-440*	1.18	–	–	–	–	A60T	100	3893-640	2.95	
4 x .035 x 3/8	19000	A60	50	3890-445*	1.18	A60T	50	6556-080	0.96	A60T	100	3893-645	2.95	
4 x 1/16 x 1/4	19000	A36	50	3890-450	1.28	A36T	100	6556-083†	1.00	A46T	50	3893-650	2.95	
4 x 1/16 x 3/8	19000	A36	50	3890-455	1.28	A36T	100	6556-086	1.00	A46T	50	3893-655	2.95	
4 x 1/8 x 1/4	19000	A24	25	3890-460	1.46	–	–	–	–	A36R	25	3893-660†	2.99	
4 x 1/8 x 3/8	19000	A24	25	3890-465	1.44	A36T	50	6556-099	1.24	A36R	25	3893-665	3.46	
4-1/2 x .045 x 7/8	13300	–	–	–	–	A60T	100	6556-103**	1.43	A60SST*	25	3893-670	2.96	
5 x .045 x 7/8	12000	–	–	–	–	A36T	25	6556-118**	1.61	A60SST*	25	3893-675	3.73	

\* 1/32" Thick, \*\* 1/16" Thick

\* For Angle Grinder Use Only † Limited Quantities



Use on Straight & Die Grinders

# Type 1 Cut-Off Wheels

## Circular Saw Wheels Fiberglass Reinforced – Resin Bonded

Designed to meet the demands of the professional contractor.  
A general purpose wheel providing fast cutting action.



1

**Buy  
Std. Ctn.  
Deduct  
10%**

			CGW			CGW			FLEXOVIT USA			FLEXOVIT USA		
			METAL, STAINLESS			MASONRY, CONCRETE			METAL, STAINLESS			MASONRY, CONCRETE		
SIZE DIA. x THICK. x ARBOR	MAX. RPM	GRADE	ORDER NO.	PRICE EACH	GRADE	ORDER NO.	PRICE EACH	GRADE	ORDER NO.	PRICE EACH	GRADE	ORDER NO.	PRICE EACH	
7 x 3/32 x 5/8	8600	A24R	3890-475	\$1.74	C24R	3890-477	\$1.82	A36TB38	3893-700	\$4.66	-	-	-	
7 x 1/8 x 5/8	8600	-	-	-	-	-	-	-	-	-	C30UB64	3893-710	\$5.00	
8 x 3/32 x 5/8	7500	-	-	-	-	-	-	A36TB38	3893-705	5.26	-	-	-	
8 x 1/8 x 5/8	7500	-	-	-	-	-	-	-	-	-	C30UB64	3893-715	5.67	

CGW –  
Std. Ctns. of 25

Flexovit USA –  
Std. Ctns. of 25

## Chopsaw/Mitre Saw Wheels Fiberglass Reinforced – Resin Bonded

Used on lower horsepower bench top chopsaws and mitre saws, these wheels combine optimum cutting speed and wheel life.

			CGW			FLEXOVIT USA			
SIZE DIA. x THICK. x ARBOR	MAX. RPM	GRADE	STD. CTN.	ORDER NO.	PRICE EACH	GRADE	STD. CTN.	ORDER NO.	PRICE EACH
12 x 3/32 x 1	5100	A36P	10	3890-510	\$3.58	A30RB	10	3893-730	\$6.98
14 x 3/32 x 1	4400	A36P	10	3890-515	4.72	A30RB	10	3893-735	9.56



## Masonry Saw Wheels Fiberglass Reinforced – Resin Bonded

A long life wheel for common brick, light aggregate cement block and fireclay.

† Limited Quantities

			CGW			FLEXOVIT USA			
SIZE DIA. x THICK. x ARBOR	MAX. RPM	GRADE	STD. CTN.	ORDER NO.	PRICE EACH	GRADE	STD. CTN.	ORDER NO.	PRICE EACH
14 x 1/8 x 1	4365	C24R	10	3890-518	\$6.96	C24RB	10	3893-740†	\$11.97



## High Speed Gas & Electric Saw Wheels Fiberglass Reinforced – Resin Bonded

Durable, hard working wheels for a variety of job site applications.



			CGW			CGW			FLEXOVIT USA			FLEXOVIT USA		
			METAL, STAINLESS			MASONRY, CONCRETE			METAL, STAINLESS			MASONRY, CONCRETE		
SIZE DIA. x THICK. x ARBOR	MAX. RPM	GRADE	ORDER NO.	PRICE EACH	GRADE	ORDER NO.	PRICE EACH	GRADE	ORDER NO.	PRICE EACH	GRADE	ORDER NO.	PRICE EACH	
12 x 1/8 x 1	6300	-	-	-	-	-	-	A24/305B	3893-800	\$6.73	C30UB	3893-820	\$6.73	
12 x 1/8 x 20MM	6300	-	-	-	-	-	-	A24/305B	3893-805	6.73	C30UB	3893-825	6.73	
12 x 5/32 x 1	6300	A24R	3890-520	\$5.12	C24R	3890-530	\$5.43	-	-	-	-	-	-	
12 x 5/32 x 20MM	6300	A24R	3890-522	5.12	C24R	3890-532	5.43	-	-	-	-	-	-	
14 x 1/8 x 1	5200	-	-	-	-	-	-	A24/305B	3893-810	11.65	C30UB	3893-830	11.65	
14 x 1/8 x 20MM	5200	-	-	-	-	-	-	A24/305B	3893-815	11.65	C30UB	3893-840	11.65	
14 x 5/32 x 1	5200	A24R	3890-524	8.98	C24R	3890-534	8.04	-	-	-	-	-	-	
14 x 5/32 x 20MM	5200	A24R	3890-526	8.98	C24R	3890-536	8.04	-	-	-	-	-	-	

CGW –  
Std. Ctns. of 10

Flexovit USA –  
Std. Ctns. of 10

## Type 1 Stationary Saw Wheels Fiberglass Reinforced – Resin Bonded

For use in production cut-off applications. Fast cutting, reliable performance.

			CGW			FLEXOVIT USA			
SIZE DIA. x THICK. x ARBOR	MAX. RPM	GRADE	STD. CTN.	ORDER NO.	PRICE EACH	GRADE	STD. CTN.	ORDER NO.	PRICE EACH
10 x 3/32 x 5/8	6130	A24R	10	3890-485	\$2.83	-	-	-	-
10 x 1/8 x 5/8	6130	A24R	10	3890-487	3.26	A30RB	10	3893-750	\$ 9.43
10 x 1/8 x 1	6130	A24R	10	3890-488	4.91	A30RB	10	3893-755	9.43
12 x 1/8 x 1	5100	A24R	10	3890-490	3.78	A30RB	10	3893-760	11.84
14 x 1/8 x 1	4300	A24R	10	3890-495	4.15	A30RB	10	3893-765	17.17
16 x 5/32 x 1	3820	A24R	10	3890-500	7.40	A30RB	10	3893-770	24.23
20 x 5/32 x 1	3050	A24R	10	3890-505	16.94	-	-	-	-
20 x 3/16 x 1	3066	-	-	-	-	A30RB	10	3893-775	43.85



# Depressed Center Wheels

1

Buy  
Std. Ctn.  
Deduct  
10%

## Type 27 General Purpose Wheels – Aluminum Oxide Fiberglass Reinforced – Resin Bonded For Metal, Stainless

For safe and efficient metal removal in all portable grinding operations. Remove weld beads, burrs, and rough edges aggressively, yet economically. Long life.



CGW							FLEXOVIT USA				
ALUMINUM OXIDE							ALUMINUM OXIDE				
SIZE DIA. x THICK. x ARBOR	MAX. RPM	GRADE	STD. CTN.	ORDER NO.	PRICE EACH	GRADE	STD. CTN.	ORDER NO.	PRICE EACH		
4 x 1/4 x 5/8	15000	A24R	25	3890-035	\$1.02	A30S	25	3890-635	\$3.13		
4-1/2 x 1/8 x 7/8	13300	A24R	25	3890-040	0.95	A30S	25	3890-640	2.45		
4-1/2 x 1/4 x 7/8	13300	A24R	25	3890-045	1.28	A30S	25	3890-645	2.48		
4-1/2 x 1/4 x 5/8-11	13300	A24R	10	3890-050	2.53	A30S	10	3890-650	4.10		
5 x 1/4 x 7/8	12000	A24R	25	3890-060	1.46	A30S	25	3890-660	4.19		
7 x 1/8 x 7/8	8600	A24R	25	3890-063	1.94	A30S	10	3890-663	5.04		
7 x 1/8 x 5/8-11	8600	A24R	10	3890-065	3.58	A30S	10	3890-665	6.88		
7 x 1/4 x 7/8	8600	A24R	25	3890-070	2.36	A30S	10	3890-670	5.18		
7 x 1/4 x 5/8-11	8600	A24R	10	3890-075	4.01	A30S	10	3890-675	7.11		
9 x 1/8 x 7/8	6800	A24R	25	3890-083	2.62	A30S	10	3890-683	7.18		
9 x 1/8 x 5/8-11	6800	A24R	10	3890-085	4.25	A30S	10	3890-685	8.89		
9 x 1/4 x 7/8	6800	A24R	25	3890-090	3.78	A30S	10	3890-690	7.45		
9 x 1/4 x 5/8-11	6800	A24R	10	3890-095	5.42	A30S	10	3890-695	9.32		

## Type 27 Premium Performance – Zirconia Aluminum Fiberglass Reinforced – Resin Bonded For Metal, Stainless Alloys



CGW							FLEXOVIT USA				
ZIRCONIA ALUMINUM							ZIRCONIA ALUMINUM				
SIZE DIA. x THICK. x ARBOR	MAX. RPM	GRADE	STD. CTN.	ORDER NO.	PRICE EACH	GRADE	STD. CTN.	ORDER NO.	PRICE EACH		
4 x 1/4 x 5/8	15000	ZA24T	25	3890-835†	\$ 2.24	-	-	-	-		
4-1/2 x 1/8 x 7/8	13300	ZA24T	25	3890-840	2.43	ZA24S	10	3890-940†	\$ 7.58		
4-1/2 x 1/4 x 7/8	13300	ZA24T	25	3890-845	3.11	ZA20Q	10	3890-945	9.27		
4-1/2 x 1/4 x 5/8-11	13300	ZA24T	10	3890-850	4.51	-	-	-	-		
7 x 1/8 x 5/8-11	8600	-	-	-	-	ZA24S	10	3890-973	13.82		
7 x 1/4 x 7/8	8600	ZA24T	25	3890-874	5.33	ZA20Q	10	3890-974	13.01		
7 x 1/4 x 5/8-11	8600	ZA24T	10	3890-875	7.05	ZA20Q	10	3890-975	14.36		
9 x 1/8 x 7/8	6800	-	-	-	-	ZA24S	10	3890-990	14.04		
9 x 1/8 x 5/8-11	6800	-	-	-	-	ZA24S	10	3890-993	15.77		
9 x 1/4 x 7/8	6800	ZA24T	25	3890-894	8.77	ZA20Q	10	3890-994	17.42		
9 x 1/4 x 5/8-11	6800	ZA24T	10	3890-895	10.49	ZA20Q	10	3890-995	18.88		

† Limited Quantities

# Depressed Center Wheels 1



# FLEXOVIT<sup>®</sup>

Buy  
Std. Ctn.  
Deduct  
**10%**

## Type 27 Quickie Cut™ Thin Reinforced Cut-Off Wheels

CGW Quickie Cut™ Thin Reinforced Type 27 Cut-Off wheels are an excellent general purpose wheel with an Aluminum Oxide / Zirconia mixture. Zirconia grain allows for faster cutting and longer life. Use on Steel and Stainless Steel.

CGW USA						FLEXOVIT USA				
SIZE DIA. x THICK. x ARBOR	SPEC	MAX. RPM	STD. CTN.	ORDER NO.	PRICE EACH	GRADE	STD. CTN.	ORDER NO.	PRICE EACH	
4 x .040 x 5/8	ZA60-S-BF	15,300	25	3898-705	\$1.34	-	-	-	-	
4 1/2 x .045 x 7/8	ZA60-S-BF	13,300	25	3898-710	1.30	A60SST	25	3893-560	\$3.46	
5 x .045 x 7/8	ZA60-S-BF	12,250	25	3898-715	1.55	A60SST	25	3893-570	3.94	
6 x .045 x 7/8	ZA60-S-BF	10,200	25	3898-720	1.72	-	-	-	-	
7 x 1/16 x 7/8	ZA60-S-BF	8,500	25	3898-725	2.53	-	-	-	-	
9 x 1/16 x 7/8	ZA60-S-BF	6,600	25	3898-730	3.11	-	-	-	-	



## Type 27 For Masonry, Concrete Silicon Carbide Depressed Center Wheels

Made with silicon carbide grain, C24R is designed for all concrete and masonry applications. Also offers fast grinding action on nonferrous materials.

CGW USA						FLEXOVIT USA					
SIZE DIA. x THICK. x ARBOR	MAX. RPM	STD. RPM	ORDER RPM	PRICE GRADE	STD. CTN.	ORDER NO.	PRICE EACH	GRADE	STD. CTN.	ORDER NO.	PRICE EACH
4-1/2 x 1/4 x 7/8	13300	8600	6600	C24R	25	3898-780	\$1.63	C24/30P	25	3893-580	\$2.75
7 x 1/4 x 5/8-11	8600	8600	6600	C24R	10	3898-785	4.91	C24/30P	10	3893-585	6.73
9 x 1/4 x 5/8-11	6600	8600	6600	C24R	10	3898-790	7.33	C24/30P	10	3893-590	9.11



## Type 28 General Purpose Wheels

### Fiberglass Reinforced – Resin Bonded For Metal, Stainless

Type 28 ("saucer shaped") wheels will grind aggressively at less than a 15 Degree angle to the workpiece, versus 30 to 45 Degrees for a Type 27 wheel. This brings the operator's elbow down to a more comfortable level in some applications, reducing fatigue.

CGW USA						FLEXOVIT USA				
SIZE DIA. x THICK. x ARBOR	MAX. RPM	GRADE	STD. CTN.	ORDER NO.	PRICE EACH	GRADE	STD. CTN.	ORDER NO.	PRICE EACH	
7 x 1/4 x 7/8	8600	A24R	25	3890-170	\$3.09	A30S	10	3890-770	\$6.93	
7 x 1/4 x 5/8-11	8600	A24R	10	3890-175	4.72	A30S	10	3890-775	8.62	
9 x 1/4 x 7/8	6800	A24R	25	3890-190	4.98	A30S	10	3890-790	10.17	
9 x 1/4 x 5/8-11	6800	A24R	10	3890-195	6.63	A30S	10	3890-795	12.02	



## Type 27 Cut/Grind/Finish Reinforced Rt. Angle Grinder Wheels

High performance wheels made to cut quickly, grind easily and finish work surfaces with ONE wheel. Fiberglass net reinforcement provides added strength and flexibility. For working on flat grinding surfaces. Most efficient when used between 0° - 15° angle. The best choice for smooth finishing. Suitable For: Steel & Stainless Steel. Contaminate free wheel has < 0.1% iron, sulfur, or chlorine for rust-free and corrosion-free results.



CGW USA					
SIZE DIA. x THICK. x ARBOR	SPEC	MAX. RPM	STD. CTN.	ORDER NO.	PRICE EACH
4 1/2 x 3/32 x 7/8	A36S	13,300	25	3898-755	\$1.46
4 1/2 x 3/32 x 5/8-11	A36S	13,300	10	3898-756	2.86
5 x 3/32 x 7/8	A36S	12,250	25	3898-760	1.79
5 x 3/32 x 5/8-11	A36S	12,250	10	3898-761	3.19
6 x 3/32 x 7/8	A36S	10,200	25	3898-765	2.59
6 x 3/32 x 5/8-11	A36S	10,200	10	3898-766	3.99

# FLEXOVIT<sup>®</sup>

## Type 27 & Type 29 Semi-Flexible Wheels

Eliminate wheel-change downtime by grinding and finishing with the same wheel. A high quality aluminum grinding product, runs virtually "load free". Performs well in all metal applications. Available in convex faced Type 29 for contoured surfaces, or Type 27 for flat surfaces. Use at a minimum 15 Degree angle. Do not use flat.

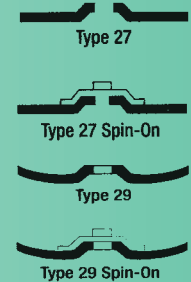

FLEXOVIT USA					
SIZE DIA. x THICK. x ARBOR	MAX. RPM	FINISH	STD. CTN.	ORDER NO.	PRICE EACH
<b>Type 27</b>					
Medium					
4-1/2 x 1/8 x 7/8	13300	24-60 Grit	25	3893-504	\$6.35
7 x 1/8 x 5/8-11	8600	24-60 Grit	10	3893-517	11.52
<b>Type 29</b>					
Medium					
7 x 1/8 x 5/8-11	8600	24-60 Grit	10	3893-547	11.52

# Abrasive Flap Discs

Zirconium Abrasive Flap Discs are used for coarse and intermediate grinding of welds, deburring, rust removal and snagging. Bridges the gap between angle grinding wheels and resin fiber discs, providing aggressive cutting action and longer life than fiber discs.

**Buy  
Std. Ctn.  
Deduct  
10%**

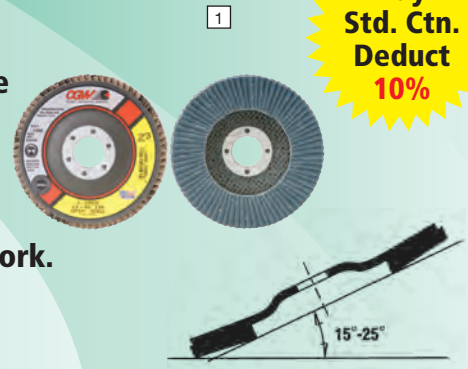

## Type 29 – Angled Style Flap Discs – Zirconium Grain

A working angle of 15 to 25 Degrees. Excellent for contour or edge work.

- Phenolic resin/fiber backing is used to prevent scratching the work piece during operation.
- Aluminum backing provides rigid support for maximum aggression; recyclable.
- CGW XL discs have approximately 60% more material.

SIZE	GRIT	STD. CTN.	VORTEC™ PHENOLIC BACKING		CGW PHENOLIC BACKING		CGW XL PHENOLIC BACKING		TIGER PHENOLIC BACKING		TIGER ALUMINUM BACKING	
			ORDER NO.	PRICE	ORDER NO.	PRICE	ORDER NO.	PRICE	ORDER NO.	PRICE	ORDER NO.	PRICE
4-1/2 x 7/8	24	10	-	-	5720-422	\$3.61	-	-	6550-601	\$5.98	6550-511	\$7.07
4-1/2 x 7/8	36	10	6531-343	\$3.20	5720-423	3.47	5720-823	\$4.36	6550-602	5.98	6550-512	7.07
4-1/2 x 7/8	40	10	6531-344	3.20	5720-424	3.47	5720-824	4.36	6550-603	5.98	6550-513	7.07
4-1/2 x 7/8	60	10	6531-345	3.20	5720-426	3.47	5720-826	4.36	6550-604	5.98	6550-514	7.07
4-1/2 x 7/8	80	10	6531-346	3.20	5720-428	3.47	5720-828	4.36	6550-605	5.98	6550-515	7.07
4-1/2 x 7/8	120	10	6531-347	3.20	5720-432	3.47	5720-832	4.36	6550-606	5.98	6550-516	7.07
7 x 7/8	40	10	-	-	5720-484	7.20	-	-	-	-	6550-533	14.14
7 x 7/8	60	10	-	-	5720-486	7.20	-	-	-	-	6550-534	14.14
7 x 7/8	80	10	-	-	5720-488	7.20	-	-	-	-	6550-535	14.14

Other sizes, and 5/8-11 Hub Style are also available. Std. Carton Qty. only.

## Type 27 – Flat Style Flap Discs

Ideal for working angles less than 15 Degrees. Smooth grinding.

### Zirconium Grain

High rate of stock removal and long life in demanding applications.

**CGW XL and Weiler Big Cat®** Abrasive Flap Discs feature a thicker disc with a higher density of flaps which conform to curved surfaces producing a consistent finish. 30% to 40% longer life than standard flap discs. For those who value parts-per-disc over price-per-disc.

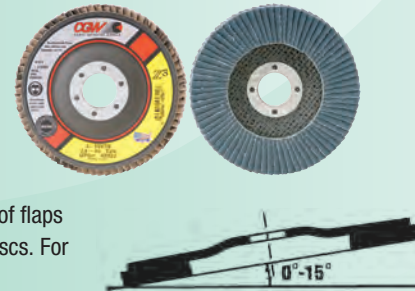

SIZE	GRIT	STD. CTN.	CGW USA MADE PHENOLIC BACKING ZIRCONIUM GRAIN		Weiler TIGER PHENOLIC BACKING ZIRCONIUM GRAIN		CGW XL USA MADE PHENOLIC BACKING ZIRCONIUM GRAIN		Weiler TIGER Big Cat® PHENOLIC BACKING ZIRCONIUM GRAIN	
			ORDER NO.	PRICE	ORDER NO.	PRICE	ORDER NO.	PRICE	ORDER NO.	PRICE
4-1/2 x 7/8	24	10	5720-222	\$3.61	-	-	-	-	-	-
4-1/2 x 7/8	36	10	5720-223	3.47	-	-	5720-623	\$4.36	-	-
4-1/2 x 7/8	40	10	5720-224	3.47	6550-703	\$5.98	5720-624	4.36	6550-803	\$ 7.52
4-1/2 x 7/8	60	10	5720-226	3.47	6550-704	5.98	5720-626	4.36	6550-804	7.52
4-1/2 x 7/8	80	10	5720-228	3.47	6550-705	5.98	5720-628	4.36	6550-805	7.52
4-1/2 x 7/8	120	10	5720-232	3.47	6550-706	5.98	5720-632	4.36	6550-806	7.52
7 x 7/8	40	10	5720-284	7.20	-	-	-	-	-	-
7 x 7/8	60	10	5720-286	7.20	-	-	-	-	-	-
7 x 7/8	80	10	5720-288	7.20	-	-	-	-	-	-

## Adapting Nuts & Spanner Wrench

– For discs with 7/8" arbor hole

DESCRIPTION	THREAD	ORDER NO.	PRICE EACH
Adapting nuts	5/8-11	6556-494	\$23.19
Spanner wrench	-	6556-495	18.66

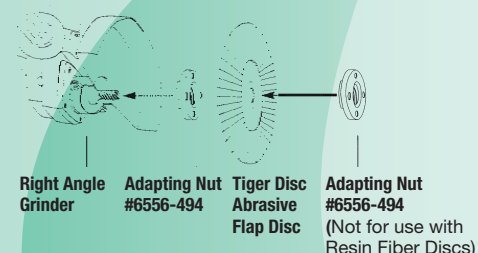



# Mini Flap Discs & Quick Change Discs

## Mini Flap Discs - Type 27 Zirconia Grain



Buy  
Std. Ctn.  
Deduct  
10%

For use on Die Grinders, these mini flap discs combine grinding and finishing applications into one step, while providing the convenience and versatility of Quick Change Discs. They are designed to prevent walking, allow access to tight areas, and reduce heat build-up.

### Applications:

- Grinding and finishing in one step.
- Grinding, deburring and blending on steel/stainless steel.
- Jobs requiring high aggression & rapid stock removal.
- Metal fabrication requiring light weld blending or edge chamfering.

CGW USA MADE									
Weiler TIGER BOBCat®									
SIZE	GRIT	RPM	PKG. QTY.	TYPE 27 (S HUB)		TYPE 27 (R HUB)		TYPE 27 (S HUB)	
				ORDER NO.	PRICE	ORDER NO.	PRICE	ORDER NO.	PRICE
2"	36	24,000	10	-	-	5722-023	\$23.46	6550-932	\$40.16
2"	40	24,000	10	5722-004	\$23.46	5722-024	23.46	6550-933	40.16
2"	60	24,000	10	5722-006	23.46	5722-026	23.46	6550-934	40.16
2"	80	24,000	10	5722-008	23.46	5722-028	23.46	6550-935	40.16
2"	120	24,000	10	5722-010	23.46	5722-030	23.46	6550-936	40.16
3"	36	20,000	10	-	-	5722-033	35.58	6550-912	51.82
3"	40	20,000	10	5722-014	35.58	5722-034	35.58	6550-913	51.82
3"	60	20,000	10	5722-016	29.42	5722-036	29.42	6550-914	51.82
3"	80	20,000	10	5722-018	29.42	5722-038	29.42	6550-915	51.82
3"	120	20,000	10	5722-020	29.42	5722-040	29.42	6550-916	51.82



## Quick Change Laminated Discs

Use on Die Grinders for deburring, blending, finishing, removing tool marks, and die polishing on all types of materials. Suitable for a wide variety of light fabrication, repair and maintenance applications. Strong 2-Ply design for flat or contour work.

- Aluminum Oxide - Color: Brown** General purpose disc for grinding, deburring, and blending on ferrous metals.
- Zirconia AO w/Grinding Aid - Color: Green** Excellent disc for rapid stock removal on Stainless Steel. Lubricated super-size Grinding Aid coat for cooler running.
- Premium Ceramic - Color: Pink** Premium grain for greater durability and aggressive cut rates, including hard metals.

Turn On style,  
(S-Hub) shown

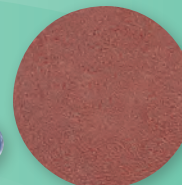
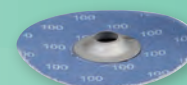

CGW												
DIAM.	GRIT	RPM	PKG. QTY.	ALUMINUM OXIDE			ZIRCONIA AO W/GRINDING AID			PREMIUM CERAMIC		
				ROLL ON (R HUB) ORDER NO.	TURN ON (S HUB) ORDER NO.	PRICE PER PACK	ROLL ON (R HUB) ORDER NO.	TURN ON (S HUB) ORDER NO.	PRICE PER PACK	ROLL ON (R HUB) ORDER NO.	TURN ON (S HUB) ORDER NO.	PRICE PER PACK
2"	36	25,000	50	5722-223	5722-623	\$23.08	5722-323	5722-723	\$32.69	5722-523	5722-923	\$36.54
	40	25,000	50	5722-224	5722-624	21.15	5722-324	5722-724	29.81	5722-524	5722-924	34.62
	50	25,000	50	5722-225	5722-625	21.15	5722-325	5722-725	29.81	5722-525	5722-925	32.69
	60	25,000	50	5722-226	5722-626	21.15	5722-326	5722-726	28.85	5722-526	5722-926	29.81
	80	25,000	50	5722-228	5722-628	20.19	5722-328	5722-728	28.85	5722-528	5722-928	27.88
	100	25,000	50	5722-230	5722-630	20.19	-	-	-	5722-530	5722-930	27.88
3"	36	20,000	25	5722-243	5722-643	18.27	5722-343	5722-743	24.04	5722-543	5722-943	34.13
	40	20,000	25	5722-244	5722-644	16.35	5722-344	5722-744	21.15	5722-544	5722-944	31.73
	50	20,000	25	5722-245	5722-645	16.35	5722-345	5722-745	21.15	5722-545	5722-945	29.33
	60	20,000	25	5722-246	5722-646	16.35	5722-346	5722-746	20.67	5722-546	5722-946	25.96
	80	20,000	25	5722-248	5722-648	15.38	5722-348	5722-748	20.67	5722-548	5722-948	24.04
	100	20,000	25	5722-250	5722-650	15.38	-	-	-	5722-550	5722-950	23.56
3"	120	20,000	25	5722-252	5722-652	15.38	5722-352	5722-752	20.67	5722-552	5722-952	23.56



## Quick Change Disc Rubber Holder Pads

- Medium grade reinforced rubber holder pad.
- Available for either internally threaded (S Hub) or externally threaded (R Hub) Quick Change discs.



SIZE	RPM	R-HUB		S-HUB	
		ORDER NO.	PRICE EACH	ORDER NO.	PRICE EACH
1"	40,000	5723-400	\$4.82	5723-410	\$5.49
1-1/2"	25,000	5723-401	5.39	5723-411	5.97
2"	25,000	5723-402	6.65	5723-412	6.99
3"	20,000	5723-403	7.36	5723-413	8.11

# Resin Fibre Discs

1

**Buy  
Std. Ctn.  
Deduct  
10%**



GRAIN SELECTOR		
GRAIN	FEATURES	APPLICATIONS
<b>Aluminum Oxide</b>	<ul style="list-style-type: none"> <li>Fast, smooth cutting action</li> <li>Tough and flexible</li> <li>High resistance to heat, glazing, and loading</li> </ul>	<ul style="list-style-type: none"> <li>All purpose weld removal and blending</li> <li>Surface preparation and finishing of ferrous metals, plastic, and wood</li> </ul>
<b>Zirconium</b>	<ul style="list-style-type: none"> <li>Superior cutting action</li> <li>More durable – longer life</li> <li>Ultra high resistance to heat, glazing, and loading</li> </ul>	<ul style="list-style-type: none"> <li>High performance grinding of stainless steel, tool steel, and hard-to-grind materials and exotic metals.</li> </ul>

				<b>CGW</b>		<b>Weller TIGER</b>		<b>USA STANDARD ABRASIVES</b>			
				ALUMINUM OXIDE		ZIRCONIUM		ALUMINUM OXIDE		ALUMINUM OXIDE	
SIZE	GRIT	STD. CTN.	ORDER NO.	PRICE	ORDER NO.	PRICE	ORDER NO.	PRICE	ORDER NO.	PRICE	
4 x 5/8	24	25	5710-152	\$0.47	-	-	-	-	-	-	
4 x 5/8	36	25	5710-153	0.47	-	-	-	-	-	-	
4 x 5/8	50	25	5710-155	0.45	-	-	-	-	-	-	
4 x 5/8	60	25	5710-156	0.43	-	-	-	-	-	-	
4 x 5/8	80	25	5710-158	0.42	-	-	-	-	-	-	
4-1/2 x 7/8	16	25	5710-201	0.56	-	-	-	-	-	-	
4-1/2 x 7/8	24	25	5710-202	0.47	5710-432	\$0.69	6559-571	\$0.97	5616-132	\$0.96	
4-1/2 x 7/8	36	25	5710-203	0.45	5710-433	0.64	6559-573	0.89	5616-133	0.95	
4-1/2 x 7/8	50	25	5710-205	0.43	5710-435	0.59	6559-575	0.84	5616-135	0.90	
4-1/2 x 7/8	60	25	5710-206	0.40	5710-436	0.56	6559-576	0.83	5616-136	0.85	
4-1/2 x 7/8	80	25	5710-208	0.38	5710-438	0.54	6559-577	0.76	5616-138	0.78	
4-1/2 x 7/8	100	25	5710-210	0.38	-	-	-	-	-	-	
4-1/2 x 7/8	120	25	5710-212	0.38	-	-	-	-	-	-	
5 x 7/8	16	25	5710-251	0.63	-	-	-	-	-	-	
5 x 7/8	24	25	5710-252	0.52	5710-462	0.73	6559-501	1.08	5616-162	1.16	
5 x 7/8	36	25	5710-253	0.49	5710-463	0.68	6559-503	1.04	5616-163	1.15	
5 x 7/8	50	25	5710-255	0.45	5710-465	0.63	6559-505	1.00	5616-165	1.07	
5 x 7/8	60	25	5710-256	0.43	5710-466	0.59	6559-506	0.89	5616-166	1.02	
5 x 7/8	80	25	5710-258	0.42	5710-468	0.57	6559-507	0.87	5616-168	0.94	
5 x 7/8	100	25	5710-260	0.42	-	-	6559-508	0.87	-	-	
5 x 7/8	120	25	5710-262	0.42	-	-	-	-	-	-	
7 x 7/8	16	25	5710-301	1.01	-	-	6559-520	1.97	-	-	
7 x 7/8	24	25	5710-302	0.90	-	-	6559-521	1.76	5616-202	1.34	
7 x 7/8	36	25	5710-303	0.83	-	-	6559-523	1.69	5616-203	1.30	
7 x 7/8	50	25	5710-305	0.82	5710-505	1.13	6559-525	1.58	5616-205	1.21	
7 x 7/8	60	25	5710-306	0.80	5710-506	1.08	6559-526	1.58	5616-206	1.16	
7 x 7/8	80	25	5710-308	0.78	5710-508	1.02	6559-527	1.45	5616-208	1.09	
7 x 7/8	100	25	5710-310	0.78	-	-	6559-528	1.45	-	-	
7 x 7/8	120	25	5710-312	0.78	-	-	6559-529	1.45	-	-	

## Spiralcool Standard Air-Cooled Backing Pads

Ideal for all sanding operations on metal, plastic, fiberglass, etc. Smooth face pads available upon request.



Supplied with 5/8-11 Arbor Hole, except the 4-1/2" which will be supplied with a 5/8" smooth bore. Other arbor holes available upon request.

SIZE	DENSITY	MAX. RPM	ORDER NO.	PRICE EACH
4"	Flexible	12,000	5710-600	\$12.80
4"	Medium	12,000	5710-601	12.80
4"	Rigid	12,000	5710-602	12.80
4-1/2"	Flexible	11,000	5710-612	12.80
4-1/2"	Medium	11,000	5710-613	12.80
4-1/2"	Rigid	11,000	5710-614	12.80
5"	Flexible	10,000	5710-624	14.50
5"	Medium	10,000	5710-625	14.50
5"	Rigid	10,000	5710-626	14.50
7"	Flexible	7,000	5710-636	21.80
7"	Medium	8,500	5710-637	21.80
7"	Rigid	8,500	5710-638	21.80
9"	Flexible	6,500	5710-648	26.05
9"	Medium	6,500	5710-649	26.05
9"	Rigid	6,500	5710-650	26.05



Nuts and wrenches do not come with pads. Must be ordered separately.

DESCRIPTION	ORDER NO.	PRICE EACH
#102 Nut; 5/8-11	5710-665	\$4.90
#103 Nut; 5/8-11 For 4" - 5" Pads	5710-666	4.90
3/8-24 - 5/8-11 Adapter	5710-660	7.85
7/16-20 - 5/8-11 Adapter	5710-661	7.85
Spanner Wrench	5710-670	4.90

# PSA Discs

## PSA Aluminum Oxide Resin Bond Cloth Discs

Abrasive cloth discs have a pressure sensitive adhesive backing making them easy to apply to a rubber disc holder. Protective liner speeds disc changing and protects adhesive from work dust. Resin bond discs are made with a heavy resin abrasive cloth, assuring long life, with fast stock removal.



2

3

2

3

2

3

IMPORT			STANDARD ABRASIVES			
GRIT	ORDER NO.	PKG QTY	PRICE PER PKG	ORDER NO.	PKG QTY	PRICE PER PKG

### 1/2" DIAMETER

120	-	-	-	5620-012	100	\$7.54
180	-	-	-	5620-018	100	7.54
240	-	-	-	5620-024	100	7.54

### 3/4" DIAMETER

60	-	-	-	5620-056	100	9.43
120	-	-	-	5620-062	100	9.43

### 1" DIAMETER

36	5711-103	100	\$11.90	-	-	-
40	5711-104	100	10.70	-	-	-
50	5711-105	100	10.70	-	-	-
60	5711-106	100	10.70	5620-106	100	\$17.91
80	5711-108	100	10.70	5620-108	100	17.91
100	5711-110	100	10.70	-	-	-
120	5711-120	100	10.70	5620-112	100	17.91
180	-	-	-	5620-118	100	17.91
240	-	-	-	5620-124	100	17.91
320	-	-	-	5620-132	100	17.91

### 1-1/2" DIAMETER

36	5711-153	100	\$15.20	-	-	-
40	5711-154	100	14.60	-	-	-
50	5711-155	100	13.90	-	-	-
60	5711-156	100	13.90	5620-156	100	\$21.69
80	5711-158	100	13.90	5620-158	100	21.69
100	5711-160	100	13.90	5620-160	100	21.69
120	5711-162	100	13.90	5620-162	100	21.69
320	-	-	-	5620-182	100	21.69

### 2" DIAMETER

36	5711-203	100	\$28.25	-	-	-
40	5711-204	100	26.90	-	-	-
50	5711-205	100	25.60	-	-	-
60	5711-206	100	24.40	5620-206	100	\$38.66
80	5711-208	100	23.25	5620-208	100	35.83
100	5711-210	100	22.05	-	-	-
120	5711-212	100	22.05	5620-212	100	34.89
240	-	-	-	5620-224	100	35.83
320	-	-	-	5620-232	100	35.83

IMPORT			STANDARD ABRASIVES			
GRIT	ORDER NO.	PKG QTY	PRICE PER PKG	ORDER NO.	PKG QTY	PRICE PER PKG

### 3" DIAMETER

36	5711-253	100	\$40.60	5620-253	100	\$49.03
40	5711-254	100	38.75	-	-	-
50	5711-255	100	36.10	-	-	-
60	5711-256	100	32.45	5620-256	100	43.37
80	5711-258	100	32.15	5620-258	100	41.49
100	5711-260	100	30.70	5620-260	100	40.54
120	5711-262	100	30.70	5620-262	100	40.54
180	-	-	-	5620-268	100	41.49
240	-	-	-	5620-274	100	41.49
320	-	-	-	5620-282	100	41.49

### 4" DIAMETER

36	-	-	-	5620-303	50	\$33.00
60	-	-	-	5620-306	50	26.40
80	-	-	-	5620-308	50	25.46
100	-	-	-	5620-310	50	24.99
180	-	-	-	5620-318	50	24.99
240	-	-	-	5620-324	50	24.99

### 5" DIAMETER

36	5711-303	50	\$40.85	5620-353	25	\$24.04
40	5711-304	50	38.50	5620-354	50	46.20
50	5711-305	50	36.40	5620-355	50	41.96
60	5711-306	50	32.35	-	-	-
80	5711-308	50	32.35	5620-358	50	38.19
100	5711-310	50	30.30	5620-360	50	36.77
120	5711-312	50	30.30	5620-362	50	36.77
180	-	-	-	5620-368	50	36.77
240	-	-	-	5620-374	50	36.77
320	-	-	-	5620-382	50	36.77

### 6" DIAMETER

36	5711-353	50	\$62.25	-	-	-
40	5711-354	50	59.70	5620-404	50	67.41
50	5711-355	50	55.50	5620-405	50	64.11
60	5711-356	50	47.80	5620-406	50	57.51
80	5711-358	50	46.90	5620-408	50	55.16
100	5711-360	50	43.90	-	-	-
120	5711-362	50	43.90	5620-412	50	53.27
180	-	-	-	5620-418	50	53.27
240	-	-	-	5620-424	50	53.27
320	-	-	-	5620-432	50	53.27

### 8" DIAMETER

36	5711-453	50	\$105.50	5620-453	10	\$25.36
40	5711-454	50	102.15	-	-	-
50	5711-455	50	94.00	5620-455	10	23.01
60	5711-456	50	87.75	5620-456	10	21.78
80	5711-458	50	79.55	5620-458	10	20.74
100	5711-460	50	77.25	5620-460	10	19.89
120	5711-462	50	77.25	5620-462	10	19.89
240	-	-	-	5620-474	10	19.89

IMPORT			STANDARD ABRASIVES			
GRIT	ORDER NO.	PKG QTY	PRICE PER PKG	ORDER NO.	PKG QTY	PRICE PER PKG

### 9" DIAMETER

36	5711-503	50	\$146.10	5620-503	10	\$36.02
40	5711-504	50	140.00	-	-	-
50	5711-505	50	126.95	-	-	-
60	5711-506	50	114.70	5620-506	10	30.17
80	5711-508	50	109.20	5620-508	10	28.47
100	5711-510	50	103.50	5620-510	10	26.87
120	-	-	-	5620-512	10	26.87

### 12" DIAMETER

24	-	-	-	5620-552	10	\$69.77
36	-	-	-	5620-553	10	60.91
40	5711-604	25	\$121.55	5620-554	10	58.55
50	5711-605	25	114.65	5620-555	10	55.35
60	5711-606	25	98.40	5620-556	10	51.10
80	5711-608	25	96.25	5620-558	10	48.27
100	5711-610	25	91.40	5620-560	10	46.58
120	5711-612	25	91.40	5620-562	10	46.58
180	-	-	-	5620-568	10	46.58
240	-	-	-	5620-574	10	46.58

### 16" DIAMETER

36	-	-	-	5620-653	10	\$114.46
40	-	-	-	5620-654	10	107.96
50	-	-	-	5620-655	10	101.83
60	-	-	-	5620-656	10	96.74
80	-	-	-	5620-658	10	90.51
120	-	-	-	5620-662	10	85.52

### 20" DIAMETER

36	-	-	-	5620-703	10	\$173.01
40	-	-	-	5620-704	10	163.77
50	-	-	-	5620-705	10	156.89
60	-	-	-	5620-706	10	145.29
80	-	-	-	5620-708	10	137.09
180	-	-	-	5620-718	10	131.81

### 24" DIAMETER

40	-	-	-	5620-754	10	\$234.39
50	-	-	-	5620-755	10	220.16

## PSA Abrasive Disc – Disc Rolls With Liner

2

Silicon Carbide Grain glue bond, "A" weight paper. Treated for load resistance, recommended for all grinding of metal, wood and fiberglass. With release paper liner and self storing dispenser. Trouble free, the most efficient disc/roll package available. No grit or dust contamination, great shelf life. Stearate coated.



5"			6"		
GRIT	PKG QTY	ORDER NO.	PRICE PER PKG	ORDER NO.	PRICE PER PKG
80	100	5712-308	\$23.05	5712-408	\$28.20
100	100	5712-310	21.95	5712-410	26.75
120	100	5712-312	21.95	5712-412	26.75
150	100	5712-315	21.95	5712-415	26.75
180	100	5712-318	21.95	5712-418	26.75
220	100	5712-322	21.95	5712-422	26.75
320	100	5712-332	21.95	5712-432	26.75

## PSA Disc Holders – Optimum performance with PSA Discs



2

DIAM.	MAX. RPM	SHK	ORDER NO.	PRICE EACH
3/4	18,000	1/4	5642-191	\$3.39
1	15,000	1/4	5642-192	4.27
1-1/2	15,000	1/4	5642-193	5.46
2	12,000	1/4	5642-194	7.07
3	10,000	1/4	5642-195	7.78

# Quick Change Discs

Available in a Choice of Quick Change Locking Systems.



## A/O 2 Ply



- Ideal for flat or contoured surfaces
- Best for MRO grinding, deburring, & finishing on ferrous metals.

## A/O Extra 2-Ply



- Ideal for flat or contoured surfaces
- Good for difficult to grind metals, such as aircraft grade aluminum, High Nickel, Chrome Alloys, & heat-sensitive material.
- Includes grinding aid

## Zirconia Pro 2-Ply

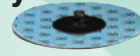

- Better choice for rapid stock removal on Stainless Steel, High Nickel Alloys, & Aluminum
- Features a grinding aid on a Y-weight backing
- Best performance under medium-to-heavy pressure

## Ceramic 2-Ply



- Best choice for rapid stock removal on Stainless Steel and High Nickel Alloys.
- Features a grinding aid for cooler operation
- Heavy pressure required

DIA.	GRIT	A/O 2 PLY				A/O EXTRA 2 PLY				ZIRCONIA PRO 2 PLY				CERAMIC 2 PLY				
		TS-STYLE ORDER NO.	TR-STYLE ORDER NO.	PKG QTY	PRICE PER PK.	TS-STYLE ORDER NO.	TR-STYLE ORDER NO.	PKG. QTY.	PRICE PER PK.	TS-STYLE ORDER NO.	TR-STYLE ORDER NO.	PKG. QTY.	PRICE PER PK.	TS-STYLE ORDER NO.	TR-STYLE ORDER NO.	PKG. QTY.	PRICE PER PK.	
1"	36	5600-103	-	50	\$16.50	5601-603	-	50	\$17.44	-	-	-	-	-	-	-	-	
	40	5600-104	-	50	16.03	-	-	-	-	-	-	-	-	-	-	-	-	
	50	5600-105	-	50	15.56	5601-605	-	50	16.03	-	-	-	-	-	5609-105	-	50	\$19.80
	60	5600-106	-	50	14.61	5601-606	-	50	15.56	-	-	-	-	-	5609-106	-	100	38.66
	80	5600-108	-	50	13.67	5601-608	-	50	15.56	-	-	-	-	-	5609-108	-	50	17.91
	100	5600-110	-	50	13.67	5601-610	-	50	15.56	-	-	-	-	-	-	-	-	-
	120	5600-112	-	50	13.67	5601-612	-	50	15.56	-	-	-	-	-	-	-	-	-
	180	5600-118	-	50	13.67	-	-	-	-	-	-	-	-	-	-	-	-	-
	240	5600-124	-	50	13.67	-	-	-	-	-	-	-	-	-	-	-	-	-
	320	5600-132	-	50	13.67	-	-	-	-	-	-	-	-	-	-	-	-	-
1-1/2"	24	5600-152	-	50	20.27	-	-	-	-	-	-	-	-	-	-	-	-	
	36	5600-153	5600-653	50	19.33	5601-653	-	50	20.27	-	5605-153	50	\$21.21	5609-153	-	50	24.04	
	40	5600-154	5600-654	50	18.86	-	-	-	-	-	-	-	-	-	-	-	-	
	50	5600-155	5600-655	50	18.86	-	-	-	-	5604-655	5605-155	50	21.21	5609-155	-	50	23.57	
	60	5600-156	5600-656	50	18.39	5601-656	-	50	19.33	5604-656	5605-156	50	20.27	5609-156	-	50	22.63	
	80	5600-158	5600-658	50	18.39	5601-658	-	50	18.86	5604-658	5605-158	50	19.80	5609-158	5609-658	50	22.16	
	100	5600-160	5600-660	50	18.39	5601-660	-	50	18.86	-	-	-	-	-	-	-	-	
	120	5600-162	5600-662	50	18.39	5601-662	-	50	18.86	5604-662	5605-162	50	19.80	5609-162	5609-662	50	22.16	
	180	5600-168	-	50	18.39	-	-	-	-	-	-	-	-	-	-	-	-	
	240	5600-174	5600-674	50	18.39	-	-	-	-	-	-	-	-	-	-	-	-	
320	5600-182	5600-682	50	18.39	-	-	-	-	-	-	-	-	-	-	-	-		
2"	24	5600-202	5600-702	50	31.59	-	-	-	-	-	-	-	-	-	-	-	-	
	36	5600-203	5600-703	50	30.17	5601-703	5602-203	50	31.11	5604-703	5605-203	50	32.53	5609-203	5609-703	50	36.77	
	40	5600-204	5600-704	50	28.76	-	-	-	-	5604-704	5605-204	50	31.59	-	-	-	-	
	50	5600-205	5600-705	50	27.34	5601-705	5602-205	50	29.23	5604-705	5605-205	50	30.64	5609-205	5609-705	50	34.89	
	60	5600-206	5600-706	50	26.40	5601-706	5602-206	50	27.81	5604-706	5605-206	50	29.70	5609-206	5609-706	50	33.47	
	80	5600-208	5600-708	50	25.93	5601-708	5602-208	50	27.34	5604-708	5605-208	50	29.70	5609-208	5609-708	50	33.47	
	100	5600-210	5600-710	50	25.93	5601-710	-	50	26.87	-	-	-	-	5609-210	-	50	33.00	
	120	5600-212	5600-712	50	25.93	5601-712	5602-212	50	26.87	5604-712	5605-212	50	29.23	5609-212	5609-712	50	33.00	
	180	5600-218	5600-718	50	25.93	-	-	-	-	-	-	-	-	-	-	-	-	
	240	5600-224	5600-724	50	25.93	-	-	-	-	-	-	-	-	-	-	-	-	
320	5600-232	5600-732	50	25.93	-	-	-	-	-	-	-	-	-	-	-	-		
3"	24	5600-302	5600-802	50	40.07	-	-	-	-	-	-	-	-	-	-	-	-	
	36	5600-303	5600-803	50	37.24	5601-803	5602-303	50	39.13	5604-803	5605-303	50	41.49	5609-303	5609-803	50	46.67	
	40	5600-304	-	50	36.30	-	-	-	-	5604-804	5605-304	50	40.54	-	-	-	-	
	50	5600-305	5600-805	50	34.89	5601-805	5602-305	50	37.24	5604-805	5605-305	50	39.13	5609-305	5609-805	50	44.31	
	60	5600-306	5600-806	50	33.94	5601-806	5602-306	50	35.83	5604-806	5605-306	50	38.19	5609-306	5609-806	50	42.90	
	80	5600-308	5600-808	50	33.00	5601-808	5602-308	50	34.89	5604-808	5605-308	50	37.24	5609-308	5609-808	50	41.96	
	100	5600-310	5600-810	50	32.53	5601-810	-	50	33.94	-	-	-	-	-	-	-	-	
	120	5600-312	5600-812	50	32.53	5601-812	-	50	33.94	5604-812	5605-312	50	36.77	5609-312	5609-812	50	41.49	
	180	5600-318	5600-818	50	36.30	-	-	-	-	-	-	-	-	-	-	-	-	
	240	5600-324	5600-824	50	32.53	-	-	-	-	-	-	-	-	-	-	-	-	
320	5600-332	5600-832	50	36.30	-	-	-	-	-	-	-	-	-	-	-	-		

## Holder Pads

For All Quick Change Style Discs 2

Available for all small diameter Quick Change style discs, in soft, medium, and firm grades.



TS (SocAtt®)

TR (Lockit®)

SIZE	DEN-SITY	MAX. RPM	TS - TA4		TR - TA4		PRICE EACH
			ORDER NO.	ORDER NO.	ORDER NO.	ORDER NO.	
3/4"	Med.	40,000	5641-014	-	-	\$10.46	
1"	Med.	40,000	5641-015	-	-	9.97	
1-1/2"	Soft	20,000	5641-016	5641-059	-	12.06	
1-1/2"	Med.	25,000	5641-017	5641-060	-	11.13	
1-1/2"	Firm	30,000	5641-018	5641-061	-	12.50	
2"	Soft	20,000	5641-019	5641-062	-	13.34	
2"	Med.	25,000	5641-020	5641-063	-	12.80	
2"	Firm	30,000	5641-021	5641-064	-	15.27	

SIZE	DEN-SITY	MAX. RPM	TS - TA4		TR - TA4		PRICE EACH
			ORDER NO.	ORDER NO.	ORDER NO.	ORDER NO.	
3"	Soft	12,000	5641-022	5641-065	-	\$16.28	
3"	Med.	20,000	5641-023	5641-066	-	14.82	
3"	Firm	20,000	5641-024	5641-067	-	17.64	
<b>5/8-1 1/2" ARBOR - LARGE DIAMETER, HARD FACE - TS HOLDER PADS</b>							
4-1/2"	Med.	18,000	5641-160	Low Profile	-	34.86	
4-1/2"	Med.	18,000	5641-150	-	-	34.86	

# Flap Wheels

Perfect tool for deburring, blending, finishing and cleaning inside and outside diameters of ferrous and non-ferrous materials.

## Mounted Flap Wheels (1"–3" Diameters) Aluminum Oxide Resin Bond

\* Permanently affixed 1/4" or 1/4-20 threaded steel shank allows choice of best system for your tooling, and fast wheel changes. Affixed mandrel for concentricity and reduced chatter; less operator fatigue.

1

**Buy  
Std. Ctn.  
Deduct  
10%**



SIZE	GRIT	STD. CTN.	1/4" SHANK				1/4-20 SHANK					
			IMPORT		Welfer TIGER		SA STANDARD ABRASIVES		Welfer TIGER		SA STANDARD ABRASIVES	
			ORDER NO.	PRICE	ORDER NO.	PRICE	ORDER NO.	PRICE	ORDER NO.	PRICE		
1" x 1"	60	10	5714-156	\$1.51	6552-003	\$3.54	5615-006	\$4.35	6552-601	\$3.54	5615-136	\$4.90
	80	10	5714-158	1.51	6552-004	3.54	5615-008	4.35	6552-603	3.54	5615-138	4.90
	120	10	5714-162	1.51	6552-005	3.54	5615-012	4.35	6552-605	3.54	5615-142	4.90
1-1/2" x 1"	60	10	5714-406	1.86	6552-009	4.41	5615-026	5.15	-	-	5615-156	5.72
	80	10	5714-408	1.86	6552-010	4.41	5615-028	5.15	-	-	5615-158	5.72
	120	10	5714-412	1.86	6552-011	4.41	5615-032	5.15	-	-	5615-162	5.72
2" x 1"	60	10	5714-556	2.19	6552-015	4.90	5615-056	6.52	6552-611	4.90	5615-186	6.59
	80	10	5714-558	2.19	6552-016	4.90	5615-058	6.52	6552-613	4.90	5615-188	6.59
	120	10	5714-562	2.22	6552-017	4.90	5615-062	6.52	-	-	5615-192	7.18
2-1/2" x 1"	60	10	5714-706	3.06	6552-486	5.30	5615-076	7.86	-	-	5615-206	8.10
	80	10	5714-708	3.06	6552-487	5.30	5615-078	7.86	-	-	5615-208	8.10
	120	10	5714-712	3.11	-	-	5615-082	7.86	-	-	5615-212	8.10
3" x 1"	60	10	5714-906	3.39	6552-027	7.09	5615-106	7.99	6552-621	7.09	5615-236	8.02
	80	10	5714-908	3.39	6552-028	7.09	5615-108	7.99	6552-623	7.09	5615-238	8.02
	120	10	5714-912	3.58	6552-029	7.09	5615-112	7.99	6552-625†	6.95	5615-242	8.72

† Limited Quantities

## Mounted Flap Wheel Drive Arbor



2

THREAD SIZE	ADAPTED SIZE	ORDER NO.	PRICE EACH
1/4-20	1/4"	5642-100	\$2.90

## Large Flap Wheels (4"–6" Diameters) Aluminum Oxide Resin Bond

\* Best Flap Wheel for applications requiring high stock removal. Provides maximum stability and smaller contact areas on work surface. Highest initial cut rate.

2

4



SIZE	GRIT	STD. CTN.	IMPORT		Welfer TIGER	
			ORDER NO.	PRICE	ORDER NO.	PRICE
4" x 1" x 5/8"	60	1	5716-156	\$ 11.50	-	-
	80	1	5716-158	11.75	6553-167†	\$19.84
	120	1	5716-162	12.40	6553-169†	21.16
6" x 1" x 1"	60	1	5716-356	18.30	6553-286	33.13
	80	1	5716-358	18.70	6553-287	35.44
	120	1	5716-362	19.65	6553-289†	36.95
6" x 2" x 1"	60	1	5716-456	27.55	6553-326	55.16
	80	1	5716-458	28.20	6553-327	58.86
	120	1	5716-462	30.30	-	-

† Limited Quantities

## Buff & Blend Combi Wheels

Wheels are constructed with alternating flaps of Buff & Blend and coated abrasive material. High rate of cut, while providing a uniform scratch pattern.

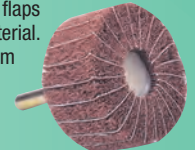

1

SIZE	GRIT	STD. CTN.	ORDER	
			NO.	PRICE
2" x 1" x 1/4"	60	10	5650-788	\$11.79
	80	10	5650-789	11.79
	120	10	5650-790	11.79
3" x 1" x 1/4"	60	10	5650-792	14.30
	80	10	5650-793	14.30
	120	10	5650-794	14.30
3" x 2" x 1/4"	60	5	5650-796	21.25
	80	5	5650-797	21.25
	120	5	5650-798	21.25
	180	5	5650-799	21.25

## Unmounted Flap Wheel Reducer Bushings

(Used in Pairs)

4

SIZE	ORDER NO.	PRICE/PAIR
1 to 1/2	6503-833	\$3.08
1 to 5/8	6503-834	2.59
1 to 3/4	6503-835	3.08



# Shop Rolls & Sanding Belts

## Cloth Shop Rolls – Aluminum Oxide

- \* For Quick Stock Removal in Metal Finishing and Polishing Applications
- \* Ability to Tear Desired Amount Eliminates Waste

2 1 3

IMPORT				MADE IN USA		STANDARD ABRASIVES	
SIZE	GRIT	ORDER NO.	PRICE	ORDER NO.	PRICE	ORDER NO.	PRICE
1"	50	-	-	-	-	5621-005	\$25.47
1"	60	5700-006	\$ 10.95	5700-306	\$25.60	5621-006	23.88
1"	80	5700-008	10.45	5700-308	24.50	5621-008	19.77
1"	100	5700-010	10.15	5700-310	23.85	5621-010	19.49
1"	120	5700-012	10.15	5700-312	23.85	5621-012	19.49
1"	150	5700-015	10.15	5700-315	23.85	5621-015	19.49
1"	180	5700-018	10.15	5700-318	23.85	5621-018	19.49
1"	220	5700-022	10.15	5700-322	23.85	-	-
1"	240	5700-024	10.15	5700-324	23.85	5621-024	19.49
1"	320	5700-032	10.15	5700-332	23.85	5621-032	19.49
1-1/2"	50	-	-	-	-	5621-105	35.57
1-1/2"	60	5700-106	15.70	5700-406	34.55	5621-106	33.60
1-1/2"	80	5700-108	14.95	5700-408	32.65	5621-108	27.72
1-1/2"	100	5700-110	14.65	5700-410	31.80	5621-110	26.70
1-1/2"	120	5700-112	14.65	5700-412	31.80	5621-112	26.70
1-1/2"	150	5700-115	14.65	5700-415	31.80	5621-115	26.70
1-1/2"	180	5700-118	14.65	5700-418	31.80	5621-118	26.70
1-1/2"	220	5700-122	14.65	5700-422	31.80	-	-
1-1/2"	240	5700-124	14.65	5700-424	31.80	5621-124	26.70
1-1/2"	320	5700-132	14.65	5700-432	31.80	5621-132	26.70
2"	50	-	-	-	-	5621-205	45.96
2"	60	5700-206	20.60	5700-506	44.70	5621-206	42.49
2"	80	5700-208	19.60	5700-508	41.35	5621-208	35.62
2"	100	5700-210	19.00	5700-510	38.65	5621-210	33.90
2"	120	5700-212	19.00	5700-512	38.65	5621-212	33.90
2"	150	5700-215	19.00	5700-515	38.65	5621-215	33.90
2"	180	5700-218	19.00	5700-518	38.65	5621-218	33.90
2"	220	5700-222	19.00	5700-522	38.65	-	-
2"	240	5700-224	19.00	5700-524	38.65	5621-224	33.90
2"	320	5700-232	19.00	5700-532	38.65	5621-232	33.90



## Cloth Sanding Belts – Aluminum Oxide

2

GRIT	PKG QTY	1 x 42"		2 x 48"		3 x 21"		3 x 24"		4 x 24"	
		ORDER NO.	PRICE PER PKG	ORDER NO.	PRICE PER PKG	ORDER NO.	PRICE PER PKG	ORDER NO.	PRICE PER PKG	ORDER NO.	PRICE PER PKG
40	10	5701-754	\$11.10	5702-754	\$19.50	5703-754	\$15.70	5703-854	\$17.20	5704-604	\$23.15
50	10	5701-755	10.70	5702-755	18.90	5703-755	15.35	5703-855	16.90	5704-605	22.05
60	10	5701-756	10.20	5702-756	18.20	5703-756	14.90	5703-856	16.65	5704-606	21.65
80	10	5701-758	9.45	5702-758	16.00	5703-758	14.00	5703-858	16.15	5704-608	20.80
100	10	5701-760	9.10	5702-760	15.55	5703-760	12.95	5703-860	15.40	5704-610	20.10
120	10	5701-762	9.10	5702-762	15.55	5703-762	12.95	5703-862	15.40	5704-612	20.10
150	10	-	-	5702-765†	15.55	5703-765	12.95	5703-865	15.40	5704-615	20.10
180	10	-	-	5702-768†	15.55	5703-768	12.95	5703-868	15.40	5704-618	20.10

† Limited Quantities

- \* X-Weight
- \* Resin Bonded
- \* Heavy Duty Construction
- \* Ideal for sanding wood or metal

Other sizes and grits available upon request. Please inquire.

GRIT	PKG QTY	4 x 36"		6 x 48"	
		ORDER NO.	PRICE PER PKG	ORDER NO.	PRICE PER PKG
40	5	-	-	5705-654	\$33.45
50	5	5704-705	\$16.55	5705-655	32.00
60	5	5704-706	16.20	5705-656	31.30
80	5	5704-708	15.45	5705-658	29.25
100	5	5704-710	14.85	5705-660	28.25
120	5	5704-712	14.85	5705-662	28.25
150	5	5704-715	14.85	5705-665	28.25
180	5	5704-718	14.85	5705-668	28.25



# Abrasive Sheets

## Quality Import

2



### Aluminum Oxide

#### 9" x 11" Cloth Sheets

- Resin Bonded
- Ideal for Sanding Wood or Metal
- Outlasts Paper by as much as 5 Times

GRIT	STD PKG	ORDER NO.	PRICE PER PKG
50	50	3273-050	\$33.65
60	50	3273-060	32.20
80	50	3273-080	31.60
100	50	3273-100	29.90
120	50	3273-120	29.90
150	50	3273-150	29.90
180	50	3273-180	29.90
220	50	3273-220	29.90
240	50	3273-240	29.90
320	50	3273-320	29.90
400	50	3273-400	29.90

### Emery

#### 9" x 11" Cloth Sheets

- Resin Bonded
- Ideal for Metal Finishing where Polishing is more important than Stock Removal

GRIT	STD PKG	ORDER NO.	PRICE PER PKG
Coarse	50	3273-500	\$32.20
Medium	50	3273-510	29.95
Fine	50	3273-520	29.95

### Crocus Cloth

#### 9" x 11" Sheets

- Resin Bonded
- Flexible cloth backing
- Used by machinists & mechanics for smoothing metal surfaces

GRIT	STD PKG	ORDER NO.	PRICE PER PKG
Fine	50	3273-700	\$42.85

### Silicon Carbide

#### 9" x 11" Waterproof Sheets

- Latex Impregnated Paper
- Offers Versatility of Wet or Dry Sanding

GRIT	STD PKG	ORDER NO.	PRICE PER PKG
100	50	3273-600	\$23.75
120	50	3273-605	23.75
150	50	3273-610	20.35
180	50	3273-615	17.10
220	50	3273-620	17.10
240	50	3273-625	17.10
280	50	3273-630	17.10
320	50	3273-635	17.10
400	50	3273-640	17.10
500	50	3273-645	17.10
600	50	3273-650	17.10
800	50	3273-655	17.10
1000	50	3273-660	17.10
1200	50	3273-665	17.10

### Silicon Carbide

#### 9" x 11" Sandscreen Sheets

- Unique Screen Mesh Prevents Loading
- Will Outlast Ordinary Sandpaper by as much as 10 Times
- Use Wet or Dry on Metal or Wood

GRIT	STD PKG	ORDER NO.	PRICE PER PKG
80	25	5718-008	\$45.30
100	25	5718-010	40.80
120	25	5718-012	40.80
150	25	5718-015	40.80
180	25	5718-018	40.80
220	25	5718-022	40.80

# Cartridge Rolls



## Straight Cartridge Rolls

Aluminum Oxide Resin Bond Cartridge Rolls feature a multi-layer, multi-wear design for long lasting durability. New abrasive cutting points are exposed throughout the life of the roll. Use for flash removal, polishing, removing machine tool marks, edge breaking, etc.



SIZE	GRIT	STD PKG	ORDER NO.	PRICE PER PKG	SIZE	GRIT	STD PKG	ORDER NO.	PRICE PER PKG	SIZE	GRIT	STD PKG	ORDER NO.	PRICE PER PKG
3/16 x 1 x 3/32	80	100	5618-001	\$21.69	3/8 x 1-1/2 x 1/8	40	100	5618-040	\$31.11	5/8 x 1-1/2 x 1/8	80	50	5618-080	28.29
3/16 x 1 x 3/32	100	100	5618-002	21.69	3/8 x 1-1/2 x 1/8	50	100	5618-041	31.11	5/8 x 1-1/2 x 3/16	60	50	5618-081	27.34
3/16 x 1 x 3/32	120	100	5618-003	22.63	3/8 x 1-1/2 x 1/8	60	100	5618-042	29.23	5/8 x 2 x 3/16	50	50	5618-084	32.06
3/16 x 1 x 3/32	180	100	5618-005	23.57	3/8 x 1-1/2 x 1/8	80	100	5618-043	31.11	5/8 x 2 x 3/16	60	50	5618-085	32.06
1/4 x 1 x 1/8	60	100	5618-008	21.69	3/8 x 1-1/2 x 1/8	100	100	5618-044	31.11	5/8 x 2 x 3/16	80	50	5618-086	34.41
1/4 x 1 x 1/8	80	100	5618-009	21.69	3/8 x 1-1/2 x 1/8	120	100	5618-045	31.11	3/4 x 1 x 1/8	80	50	5618-089	26.40
1/4 x 1 x 1/8	100	100	5618-010	22.63	3/8 x 1-1/2 x 1/8	180	100	5618-047	33.94	3/4 x 1 x 3/16	40	50	5618-090	24.99
1/4 x 1 x 1/8	120	100	5618-011	22.63	3/8 x 1-1/2 x 1/8	240	100	5618-048	33.94	3/4 x 1 x 3/16	80	50	5618-091	26.40
1/4 x 1 x 1/8	180	100	5618-012	23.57	3/8 x 2 x 1/8	60	100	5618-050	35.83	3/4 x 1-1/2 x 1/8	60	50	5618-092	32.53
1/4 x 1 x 1/8	240	100	5618-013	24.51	3/8 x 2 x 1/8	80	100	5618-051	37.71	3/4 x 1-1/2 x 1/8	80	50	5618-093	33.00
1/4 x 1 x 1/8	320	100	5618-014	24.51	3/8 x 2 x 1/8	100	100	5618-052	37.71	3/4 x 1-1/2 x 3/16	36	50	5618-094	33.00
1/4 x 1-1/2 x 1/8	60	100	5618-015	26.40	3/8 x 2 x 1/8	120	100	5618-053	38.66	3/4 x 1-1/2 x 3/16	60	50	5618-095	32.53
1/4 x 1-1/2 x 1/8	80	100	5618-016	27.34	1/2 x 1 x 1/8	60	100	5618-055	27.34	3/4 x 1-1/2 x 3/16	80	50	5618-096	32.06
1/4 x 1-1/2 x 1/8	100	100	5618-017	28.29	1/2 x 1 x 1/8	80	100	5618-056	28.29	3/4 x 1-1/2 x 3/16	120	50	5618-097	32.53
1/4 x 1-1/2 x 1/8	120	100	5618-018	27.34	1/2 x 1 x 1/8	100	100	5618-057	29.23	3/4 x 1-1/2 x 1/4	60	50	5618-098	32.53
1/4 x 1-1/2 x 1/8	150	100	5618-019	29.23	1/2 x 1 x 1/8	120	100	5618-058	29.23	3/4 x 1-1/2 x 1/4	80	50	5618-099	33.00
1/4 x 1-1/2 x 1/8	180	100	5618-020	29.23	1/2 x 1-1/2 x 1/8	36	100	5618-060	41.49	3/4 x 1-1/2 x 1/4	120	50	5618-100	33.94
1/4 x 1-1/2 x 1/8	320	100	5618-021	29.23	1/2 x 1-1/2 x 1/8	40	100	5618-061	40.54	3/4 x 2 x 3/16	40	25	5618-102	20.51
1/4 x 1-1/2 x 1/8	400	100	5618-022	31.11	1/2 x 1-1/2 x 1/8	50	100	5618-062	40.54	3/4 x 2 x 3/16	60	25	5618-103	20.51
1/4 x 2 x 1/8	80	100	5618-023	34.89	1/2 x 1-1/2 x 1/8	60	100	5618-063	38.66	3/4 x 2 x 3/16	80	25	5618-104	21.69
1/4 x 2 x 1/8	100	100	5618-024	34.89	1/2 x 1-1/2 x 1/8	80	100	5618-064	39.60	3/4 x 2 x 3/16	100	25	5618-105	22.16
1/4 x 2 x 1/8	120	100	5618-025	35.83	1/2 x 1-1/2 x 1/8	100	100	5618-065	40.54	3/4 x 2 x 3/16	120	25	5618-106	21.69
5/16 x 1 x 1/8	120	100	5618-028	26.40	1/2 x 1-1/2 x 1/8	120	100	5618-066	38.66	3/4 x 2 x 3/16	60	25	5618-107	20.51
5/16 x 1-1/2 x 1/8	80	100	5618-030	31.11	1/2 x 1-1/2 x 1/8	180	100	5618-067	41.49	3/4 x 2 x 1/4	80	25	5618-108	22.39
5/16 x 1-1/2 x 1/8	100	100	5618-031	33.00	1/2 x 1-1/2 x 1/8	240	100	5618-069	43.37	3/4 x 2 x 1/4	120	25	5618-110	22.39
5/16 x 1-1/2 x 1/8	120	100	5618-032	33.94	1/2 x 2 x 1/8	60	50	5618-071	23.57	1 x 1-1/2 x 1/4	60	25	5618-111	27.81
3/8 x 1 x 1/8	60	100	5618-034	24.51	1/2 x 2 x 1/8	80	50	5618-072	24.04	1 x 1-1/2 x 1/4	80	25	5618-112	28.76
3/8 x 1 x 1/8	80	100	5618-035	24.51	1/2 x 2 x 1/8	120	50	5618-074	24.04	1 x 2 x 1/4	60	25	5618-113	34.65
3/8 x 1 x 1/8	100	100	5618-036	24.51	1/2 x 2 x 3/16	60	50	5618-075	23.57	1 x 2 x 1/4	80	25	5618-114	35.83
3/8 x 1 x 1/8	120	100	5618-037	24.51	1/2 x 2 x 3/16	100	50	5618-077	24.04					
3/8 x 1 x 1/8	180	100	5618-038	26.40	1/2 x 2 x 1/4	40	50	5618-078	24.04					
3/8 x 1 x 1/8	240	100	5618-039	26.40										



# Cartridge Rolls

## Full Taper Cartridge Rolls



SIZE	GRIT	STD PKG	ORDER NO.	PRICE PER PKG	SIZE	GRIT	STD PKG	ORDER NO.	PRICE PER PKG	SIZE	GRIT	STD PKG	ORDER NO.	PRICE PER PKG
3/8 x 1 x 1/8	60	100	5618-300	\$46.20	1/2 x 1-1/2 x 1/8	36	100	5618-312	\$55.63	1/2 x 2 x 1/8	60	50	5618-319	\$28.76
3/8 x 1 x 1/8	80	100	5618-301	48.09	1/2 x 1-1/2 x 1/8	50	100	5618-313	53.74	1/2 x 2 x 1/8	80	50	5618-320	29.23
3/8 x 1 x 1/8	120	100	5618-302	48.09	1/2 x 1-1/2 x 1/8	60	100	5618-314	52.80	1/2 x 2 x 1/8	180	50	5618-321	30.64
3/8 x 1 x 1/8	180	100	5618-303	48.09	1/2 x 1-1/2 x 1/8	80	100	5618-315	53.74	3/4 x 1-1/2 x 1/8	80	50	5618-324	37.71
3/8 x 1-1/2 x 1/8	60	100	5618-305	51.86	1/2 x 1-1/2 x 1/8	100	100	5618-316	54.69	3/4 x 1-1/2 x 3/16	50	50	5618-325	36.77
3/8 x 1-1/2 x 1/8	80	100	5618-306	49.97	1/2 x 1-1/2 x 1/8	120	100	5618-317	53.74	3/4 x 1-1/2 x 3/16	60	50	5618-326	36.77
3/8 x 1-1/2 x 1/8	120	100	5618-307	49.97	1/2 x 1-1/2 x 1/8	180	100	5618-318	55.63	3/4 x 1-1/2 x 3/16	80	50	5618-327	37.71

# Mandrels For Cartridge Rolls

- Cartridge Rolls of 3/4" length – 1/2" Pilot Length
- Cartridge Rolls of 1" length – 3/4" Pilot Length
- Cartridge Rolls of 1-1/2" length – 1" Pilot Length
- Cartridge Rolls of 2" length – 1-1/2" Pilot Length
- Cartridge Rolls of 2-1/2" length – 2" Pilot Length

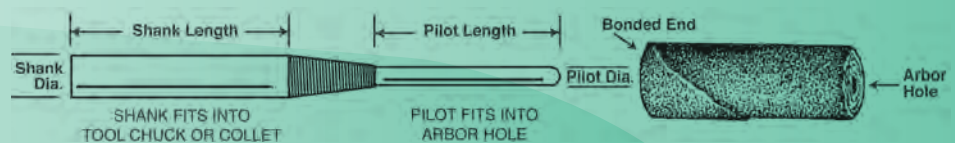

DESCRIPTION	PILOT DIA.	PILOT LGTH	SHANK DIA.	SHANK LGTH	O/A LGTH	ORDER NO.	PRICE EACH	DESCRIPTION	PILOT DIA.	PILOT LGTH	SHANK DIA.	SHANK LGTH	O/A LGTH	ORDER NO.	PRICE EACH
CM-2B	3/32	3/4	1/8	1	2-3/4	5642-150	\$2.81	CM-10	1/8	1-1/2	1/4	1-1/4	3-1/4	5642-161	\$2.72
CM-2E	3/32	3/4	1/4	1	2-3/4	5642-152	3.17	CM-11	1/8	2	1/4	1-1/4	4	5642-162	3.46
CM-2F	3/32	1	1/4	1-1/4	3	5642-153	3.17	CM-15	3/16	3/4	1/4	1-1/4	2-1/2	5642-163	3.17
CM-3	1/8	1/2	1/8	1	2-1/2	5642-154	2.81	CM-16	3/16	1	1/4	1-1/4	2-1/2	5642-164	3.17
CM-4	1/8	3/4	1/8	1	2-3/4	5642-155	2.81	CM-17	3/16	1-1/2	1/4	1-1/4	3-3/8	5642-165	3.61
CM-5	1/8	1	1/8	1	2-1/2	5642-156	2.81	CM-18	3/16	2	1/4	1-1/4	4	5642-166	3.61
CM-6	1/8	1-1/2	1/8	1	3-1/2	5642-157	3.17	CM-21	1/4	1	1/4	1-1/4	3	5642-168	3.17
CM-7	1/8	1/2	1/4	1-1/4	2-1/4	5642-158	3.17	CM-22	1/4	1-1/2	1/4	1-1/4	3-1/2	5642-169	3.61
CM-8	1/8	3/4	1/4	1-1/4	2-1/2	5642-159	3.17	CM-23	1/4	2	1/4	1-1/4	4	5642-170	3.61
CM-9	1/8	1	1/4	1-1/4	2-3/4	5642-160	2.72								

# Non-Woven Abrasives



## Surface Conditioning Discs Quick Change Discs, Aluminum Oxide (A/O), FE

Type "FE" material is very flexible, with high edge durability. FE provides a high initial and extended rate of cut. Performs well on flat and contoured surfaces. Ideal on a variety of deburring, blending and cleaning applications.

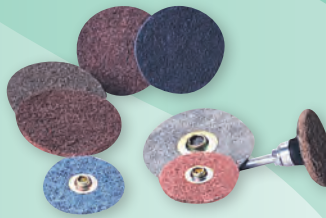

SIZE	GRIT	MAX. RPM	TS-STYLE		TR-STYLE		HOOK & LOOP		
			ORDER NO.	ORDER NO.	MAX. RPM	ORDER NO.	PKG QTY	PRICE PER PKG	
1"	Coarse	12,000 - 20,000	5650-103	5650-127	-	-	50	\$28.76	
1"	Medium	12,000 - 20,000	5650-104	5650-128	-	-	50	28.76	
1"	Very Fine	12,000 - 20,000	5650-105	5650-129	-	-	50	28.76	
1-1/2"	Coarse	12,000 - 20,000	5650-106	5650-130	-	-	50	32.06	
1-1/2"	Medium	12,000 - 20,000	5650-107	5650-131	-	-	50	32.06	
1-1/2"	Very Fine	12,000 - 20,000	5650-108	5650-132	-	-	50	32.06	
2"	Coarse	12,000 - 20,000	5650-109	5650-133	-	-	50	46.20	
2"	Medium	12,000 - 20,000	5650-110	5650-134	-	-	50	46.20	
2"	Very Fine	12,000 - 20,000	5650-111	5650-135	-	-	50	46.20	
3"	Coarse	10,000 - 18,000	5650-112	5650-136	-	-	25	44.08	
3"	Medium	10,000 - 18,000	5650-113	5650-137	-	-	25	44.08	
3"	Very Fine	10,000 - 18,000	5650-114	5650-138	-	-	25	44.08	
4-1/2"	Coarse	-	-	-	6,000 - 8,000	5650-256	10	29.42	
4-1/2"	Medium	-	-	-	6,000 - 8,000	5650-257	10	25.74	
4-1/2"	Very Fine	-	-	-	6,000 - 8,000	5650-258	10	25.74	
5"	Coarse	-	-	-	5,000 - 7,000	5650-259	10	35.36	
5"	Medium	-	-	-	5,000 - 7,000	5650-260	10	30.64	
5"	Very Fine	-	-	-	5,000 - 7,000	5650-261	10	30.64	
7"	Coarse	-	-	-	3,000 - 6,000	5650-262	10	60.25	
7"	Medium	-	-	-	3,000 - 6,000	5650-263	10	53.93	
7"	Very Fine	-	-	-	3,000 - 6,000	5650-264	10	53.93	

Type "GP" Surface Conditioning Discs are also available upon request. Call for delivery. Not as flexible as Type "FE", works especially well on flat surfaces.

## Holder Pads For All Quick Change Style Discs

Available for all small diameter Quick Change style discs, in soft, medium and firm grades.

SIZE	DENSITY	MAX. RPM	TS-STYLE w/TA4		PRICE EACH
			ORDER NO.	ORDER NO.	
3/4"	Medium	40,000	5641-014	-	\$ 10.46
1"	Medium	40,000	5641-015	-	9.97
1-1/2"	Soft	20,000	5641-016	5641-059	12.06
1-1/2"	Medium	25,000	5641-017	5641-060	11.13
1-1/2"	Firm	30,000	5641-018	5641-061	12.50
2"	Soft	20,000	5641-019	5641-062	13.34
2"	Medium	25,000	5641-020	5641-063	12.80
2"	Firm	30,000	5641-021	5641-064	15.27
3"	Soft	12,000	5641-022	5641-065	16.28
3"	Medium	20,000	5641-023	5641-066	14.82
3"	Firm	20,000	5641-024	5641-067	17.64



## Holder Pads For Hook & Loop Style Discs

SIZE	MAX. RPM	ORDER NO.	PRICE EACH
4-1/2" with 5/8-11	10,000	5642-502	\$27.15
5" with 5/8-11	10,000	5642-503	27.15
7" with 5/8-11	6,000	5642-504	31.88

## High Strength Buff & Blend Discs With Center Hole, Aluminum Oxide (A/O)

The best product for finishing and light deburring applications. A very conformable and durable tool for finishing and polishing applications on metals, plastics and glass.



SIZE	HOLE	GRADE	MAX. RPM	PKG QTY	ORDER NO.	PRICE PER PKG
5"	1/2"	Very Fine	4,000	10	5650-670	\$20.18
6"	1/2"	Very Fine	3,600	10	5650-671	25.46
7"	1/2"	Very Fine	3,000	10	5650-672	34.60
8"	1/2"	Very Fine	2,700	10	5650-673	41.77
10"	1/2"	Very Fine	2,000	10	5650-674	56.10
12"	1-1/4"	Very Fine	1,800	5	5650-675	37.24

## Buff & Blend Discs

### Buff & Blend Quick Change "GP" Discs, Aluminum Oxide (A/O)

Flexible, conformable discs constructed of GP material, which provides a high rate of cut while producing consistent finishes. Applications include blending, cleaning, deburring and finishing.

SIZE	GRIT	MAX. RPM	PKG QTY	TS-STYLE		PRICE PER PKG
				ORDER NO.	ORDER NO.	
1-1/2"	Medium	12,000	50	5650-506	5650-536	\$42.43
1-1/2"	Fine	12,000	50	5650-507	5650-537	41.01
1-1/2"	Very Fine	12,000	50	5650-508	-	41.01
2"	Medium	12,000	50	5650-509	5650-539	46.20
2"	Fine	12,000	50	5650-510	5650-540	43.37
2"	Very Fine	12,000	50	5650-511	5650-541	43.37
3"	Medium	8,000	25	5650-512	5650-542	37.48
3"	Fine	8,000	25	5650-513	5650-543	34.18
3"	Very Fine	8,000	25	5650-514	5650-544	34.18

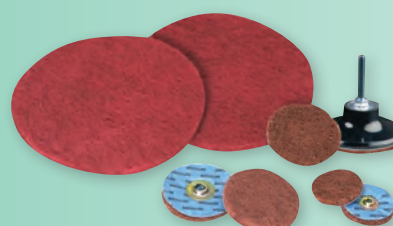

TS (SocAtt®)

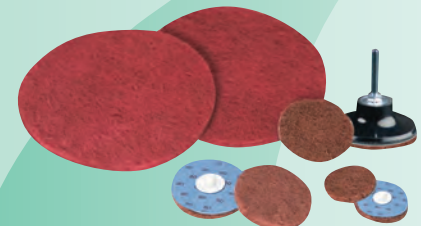

TR (Lockit®)

# Non-Woven Abrasives

## Type 27 Unitized Discs

Manufactured from the highest quality Unitized material. Unique design offers material removal while imparting a final finish. Used in conjunction with, and sometimes in lieu of, a coated abrasive Resin Fibre Disc or Flap Disc.



**Buy  
Std. Ctn.  
Deduct  
10%\***

\*excluding accessories

- Deburring
- Edge Breaking
- Blending
- Cleaning
- Final Polishing

500	Soft Density - Finishing & Polishing
600	Medium Density - Blending & Polishing
700	Medium Density - Deburring & Cleaning
800	Hard Density - Deburring

1

SIZE	SERIES	STD. CTN.	ORDER NO.	PRICE EACH
4-1/2 x 7/8	532	5	5651-130	\$17.85
4-1/2 x 7/8	632	5	5651-131	19.49
4-1/2 x 7/8	732	5	5651-132	20.37
4-1/2 x 7/8	821	5	5651-135	23.26
4-1/2 x 7/8	811	5	5651-133	23.26

## Quick Change Surface Conditioning Discs

Use on Die Grinders for deburring, blending, finishing, cleaning and polishing. Suitable for a wide variety of light fabrication, repair and for stainless steel, and ferrous & non-ferrous metals.



Roll On style, (R-Hub) shown

4

CGW			ALUMINUM OXIDE			
DIAM.	GRIT	RPM	PKG. QTY.	ROLL ON (R HUB) ORDER NO.	TURN ON (S HUB) ORDER NO.	PRICE PER PACK
2"	Coarse	25,000	50	5723-300	5723-320	\$42.31
	Medium	25,000	50	5723-301	5723-321	42.31
	A Very Fine	25,000	50	5723-302	5723-322	40.38
3"	Coarse	20,000	25	5723-305	5723-325	39.42
	Medium	20,000	25	5723-306	5723-326	39.42
	A Very Fine	20,000	25	5723-307	5723-327	37.50

# Non-Woven Abrasives



3

## Convolute Wheels

Convolute Wheels are constructed by wrapping non-woven nylon, impregnated throughout with abrasive grain, around a hard core.

## GP Plus Wheels

Removes medium to heavy burrs and edge breaking.

SIZE	GRAIN	SPEC.	GRADE	MAX. RPM	ORDER NO.	PRICE EACH
6 x 1/2 x 1	S/C	8SF	Fine	6,000	5651-880	\$ 45.54
6 x 1/2 x 1	S/C	8SM	Medium	6,000	5651-882	46.07
6 x 1/2 x 1	S/C	9SF	Fine	6,000	5651-881	45.54
6 x 1 x 1	S/C	8SF	Fine	6,000	5651-884	63.75
6 x 1 x 1	S/C	8SM	Medium	6,000	5651-887	64.50
6 x 1 x 1	S/C	9SF	Fine	6,000	5651-885	63.75
6 x 2 x 1	S/C	9SF	Fine	6,000	5651-888	113.54
8 x 1/2 x 3	S/C	8SF	Fine	4,500	5651-892	54.18
8 x 1/2 x 3	S/C	9SF	Fine	4,500	5651-893	54.18
8 x 1 x 3	S/C	8SF	Fine	4,500	5651-896	79.74
8 x 1 x 3	S/C	8SM	Medium	4,500	5651-894	80.63
8 x 1 x 3	S/C	9SF	Fine	4,500	5651-897	79.74
8 x 2 x 3	S/C	8SF	Fine	4,500	5651-900	139.03
8 x 2 x 3	S/C	8SM	Medium	4,500	5651-901	140.65
12 x 1/2 x 5	S/C	8SF	Fine	3,000	5651-904	76.44
12 x 1 x 5	S/C	8SF	Fine	3,000	5651-908	125.09
12 x 1 x 5	S/C	9SF	Fine	3,000	5651-909	125.09
12 x 2 x 5	S/C	8SF	Fine	3,000	5651-912	222.38
12 x 2 x 5	S/C	9SF	Fine	3,000	5651-913	222.38

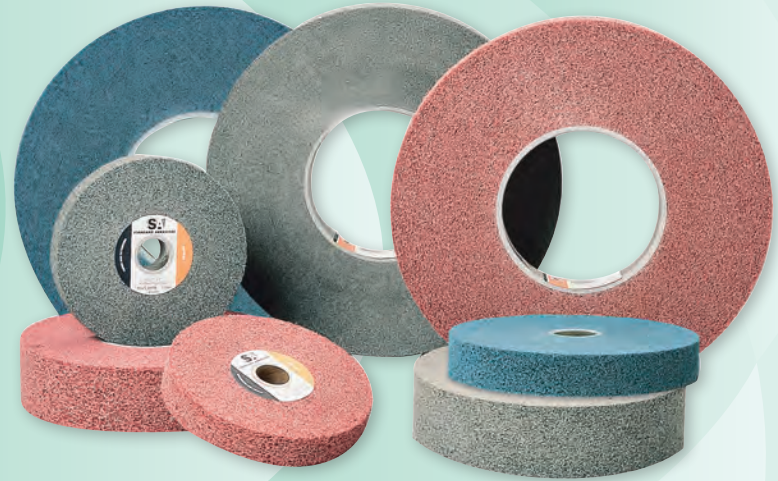

## Deburring Wheels

Excellent starting point for medium to heavy deburring and polishing.

SIZE	DENSITY	GRAIN	GRADE	MAX. RPM	ORDER NO.	PRICE EACH
6 x 1/2 x 1	Medium	S/C	Fine	6,000	5651-002	\$46.07
6 x 1/2 x 1	Hard	S/C	Fine	6,000	5651-003	46.07
6 x 1 x 1	Medium	S/C	Fine	6,000	5651-006	64.50
6 x 1 x 1	Hard	S/C	Fine	6,000	5651-007	64.50
6 x 2 x 1	Hard	S/C	Fine	6,000	5651-008	105.32
8 x 1/2 x 3	Hard	S/C	Fine	4,500	5651-010	54.81
8 x 1 x 3	Medium	S/C	Fine	4,500	5651-013	80.63
8 x 1 x 3	Hard	S/C	Fine	4,500	5651-014	80.63

## LDW (Light Deburring Wheels)

Removes light burrs; use prior to polishing.

SIZE	GRAIN	SPEC.	GRADE	MAX. RPM	ORDER NO.	PRICE EACH
6 x 1/2 x 1	S/C	6SF	Fine	6,000	5651-920	\$ 46.19
6 x 1/2 x 1	S/C	7SF	Fine	6,000	5651-921	49.25
6 x 1/2 x 1	S/C	8SF	Fine	6,000	5651-922	49.25
6 x 1 x 1	S/C	6SF	Fine	6,000	5651-926	64.65
#6 x 1 x 1	S/C	7SF	Fine	6,000	5651-927	68.96
6 x 1 x 1	S/C	8SF	Fine	6,000	5651-928	68.96
8 x 1/2 x 3	S/C	8SF	Fine	4,500	5651-934	58.62
8 x 1 x 3	S/C	7SF	Fine	4,500	5651-939	86.27
8 x 1 x 3	S/C	8SF	Fine	4,500	5651-940	86.27
12 x 1/2 x 5	S/C	7SF	Fine	3,000	5651-945	75.79
12 x 1/2 x 5	S/C	8SF	Fine	3,000	5651-946	75.79
12 x 1 x 5	S/C	7SF	Fine	3,000	5651-951	124.00
12 x 1 x 5	S/C	8SF	Fine	3,000	5651-952	124.00
12 x 2 x 5	S/C	8SF	Fine	3,000	5651-958	220.46

# Non-Woven Abrasives



## Standard Abrasives - Unitized Mounted Points

Unitized Mounted Points are made from high durability material and are available in standard ANSI shapes for varying workpiece dimensions and applications.



### Series:

- 600 - High Durability, Medium density (Blending/Polishing)
- 700 - High Durability, Medium density (Deburring/Cleaning)
- 800 - High Durability, Hard density (Deburring/Cleaning)

### Size Chart:

A SHAPES							
SHAPE	MAX. RPM	SERIES	GRAIN	GRADE	PKG QTY	ORDER NO.	PRICE EACH
A21	34,500	632	S/C	Fine	5	5651-501	\$11.15
A21	34,500	731	A/O	Fine	5	5651-502	12.91
A21	34,500	732	S/C	Fine	5	5651-503	12.91
A21	34,500	811	A/O	Coarse	5	5651-504	13.01
A21	34,500	821	A/O	Medium	5	5651-505	13.01
A25	35,600	811	A/O	Coarse	5	5651-506	12.93
A25	35,600	821	A/O	Medium	5	5651-507	12.93

SHAPE	SIZE
A21	1" x 1" x 1/4"
A25	1" x 1" x 1/4"
B52	3/8" x 3/4" x 1/8"
B90	1/2" x 1/2" x 1/8"
B121	1/2" x 1/2" x 1/8"

SHAPE	SIZE
W160	1/4" x 1/4" x 1/8"
W163	1/4" x 1/2" x 1/8"
W183	1/2" x 1/4" x 1/8"
W185	1/2" x 1/2" x 1/8"
W220	1" x 1" x 1/4"

B SHAPES							
SHAPE	MAX. RPM	SERIES	GRAIN	GRADE	PKG QTY	ORDER NO.	PRICE EACH
B52	45,300	731	A/O	Fine	5	5651-508	\$5.24
B52	45,300	732	S/C	Fine	5	5651-509	5.24
B52	45,300	811	A/O	Coarse	5	5651-510	5.47
B52	45,300	821	A/O	Medium	5	5651-511	5.47
B90	34,500	731	A/O	Fine	5	5651-512	4.16
B90	34,500	732	S/C	Fine	5	5651-513	4.16
B90	34,500	821	A/O	Medium	5	5651-515	4.73
B121	45,300	731	A/O	Fine	5	5651-516	4.54
B121	45,300	811	A/O	Coarse	5	5651-517	4.97
B121	45,300	821	A/O	Medium	5	5651-518	4.97

W SHAPES							
SHAPE	MAX. RPM	SERIES	GRAIN	GRADE	PKG QTY	ORDER NO.	PRICE EACH
W160	81,300	811	A/O	Coarse	5	5651-519	\$2.79
W160	81,300	821	A/O	Medium	5	5651-520	2.79
W163	60,000	811	A/O	Coarse	5	5651-521	3.30
W163	60,000	821	A/O	Medium	5	5651-522	3.30
W183	51,700	632	S/C	Fine	5	5651-523	3.17
W183	51,700	731	A/O	Fine	5	5651-524	3.30
W183	51,700	732	S/C	Fine	5	5651-525	3.32
W183	51,700	811	A/O	Coarse	5	5651-526	3.62
W183	51,700	821	A/O	Medium	5	5651-527	3.62
W185	34,500	631	A/O	Fine	5	5651-528	3.93
W185	34,500	632	S/C	Fine	5	5651-529	3.93
W185	34,500	731	A/O	Fine	5	5651-530	4.15
W185	34,500	732	S/C	Fine	5	5651-531	4.15
W185	34,500	811	A/O	Coarse	5	5651-532	4.58
W185	34,500	821	A/O	Medium	5	5651-533	4.58
W220	25,000	811	A/O	Coarse	5	5651-534	12.57
W220	25,000	821	A/O	Medium	5	5651-535	12.57

## 6" x 9" Hand Pads

Hand Pads are flexible, washable, and conform to workpiece. Ideal for hand applications on metals, composite or plastic surfaces. Use for cleaning, finishing or polishing. Color coded.



## Hand Pad Holder

For use with 3" x 6" pads

Order No. 5642-520

Price each..... \$16.71

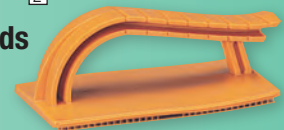

COLOR CODE	APPLICATION	IMPORT			TIGER			STANDARD ABRASIVES		
		ORDER NO.	PKG QTY	PRICE PER PKG	ORDER NO.	PKG QTY	PRICE PER PKG	ORDER NO.	PKG QTY	PRICE PER PKG
White	Non-Abrasive Pad For Polishing and Light Cleaning	5718-100	20	\$15.80	-	-	-	5651-700	60	\$55.52
Grey	Ultra-Fine S/C Abrasive Pad For Free Hand Cleaning & Finishing Usable with mild detergents	5718-105	20	15.80	6551-434	60	\$77.00	5651-705	60	54.58
Maroon	General Purpose A/O Abrasive Pad For Basic Cleaning and Finishing Usable with most solvents	5718-110	20	15.80	6551-444	60	77.83	5651-710	60	54.58
					6551-460	60	58.79			
Tan	Heavy Duty A/O Abrasive Pad For Heavy Duty Cleaning or Fast Action Finishing Usable with most solvents	5718-120	10	21.00	6551-454	40	124.48	5651-720	40	91.56

## Scouring Hand Pads

Green	Industrial	5718-115	20	15.80	-	-	-	5651-715	60	56.65
Green	Commercial (Food Processing)	-	-	-	6551-457	60	61.69	-	-	-